

UNIT -1

1.1 OVERVIEW OF LANGUAGE PROCESSING SYSTEM

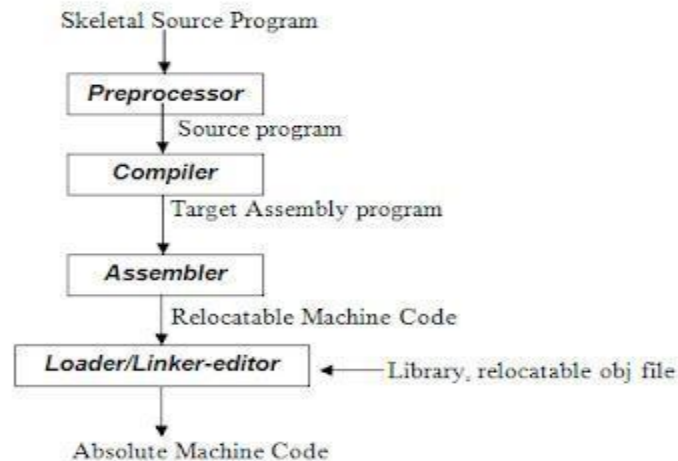

Fig 1.1 Language –processing System

1.2 Preprocessor

A preprocessor produce input to compilers. They may perform the following functions.

1. *Macro processing*: A preprocessor may allow a user to define macros that are short hands for longer constructs.
2. *File inclusion*: A preprocessor may include header files into the program text.
3. *Rational preprocessor*: these preprocessors augment older languages with more modern flow-of-control and data structuring facilities.
4. *Language Extensions*: These preprocessor attempts to add capabilities to the language by certain amounts to build-in macro

1.3 COMPILER

Compiler is a translator program that translates a program written in (HLL) the source program and translate it into an equivalent program in (MLL) the target program. As an important part of a compiler is error showing to the programmer.

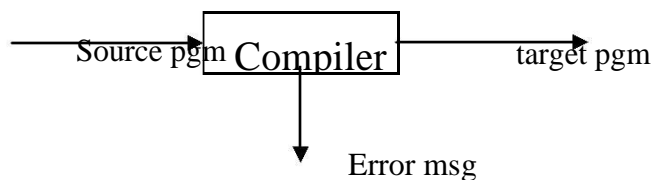

Executing a program written in HLL programming language is basically of two parts. the source program must first be compiled translated into a object program. Then the results object program is loaded into a memory executed.

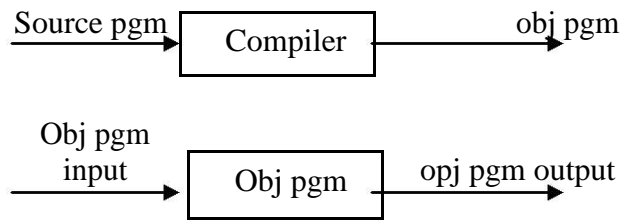

1.4 ASSEMBLER: programmers found it difficult to write or read programs in machine language. They begin to use a mnemonic (symbols) for each machine instruction, which they would subsequently translate into machine language. Such a mnemonic machine language is now called an assembly language. Programs known as assembler were written to automate the translation of assembly language into machine language. The input to an assembler program is called source program, the output is a machine language translation (object program).

1.5 INTERPRETER: An interpreter is a program that appears to execute a source program as if it were machine language.

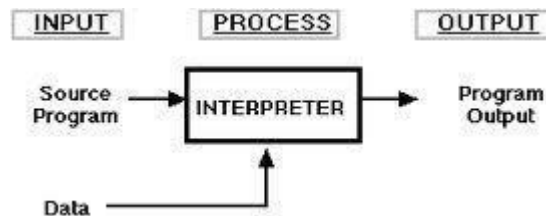

Languages such as BASIC, SNOBOL, LISP can be translated using interpreters. JAVA also uses interpreter. The process of interpretation can be carried out in following phases.

1. Lexical analysis
2. Syntax analysis
3. Semantic analysis
4. Direct Execution

Advantages:

- Modification of user program can be easily made and implemented as execution proceeds.
- Type of object that denotes a various may change dynamically.
- Debugging a program and finding errors is simplified task for a program used for interpretation.
- The interpreter for the language makes it machine independent.

Disadvantages:

The execution of the program is *slower*.
Memory consumption is more.

2 *Loader and Link-editor:*

Once the assembler produces an object program, that program must be placed into memory and executed. The assembler could place the object program directly in memory and transfer control to it, thereby causing the machine language program to be executed. This would waste core by leaving the assembler in memory while the user's program was being executed. Also the programmer would have to retranslate his program with each execution, thus wasting translation time. To overcome these problems of wasted translation time and memory. System programmers developed another component called loader

“A loader is a program that places programs into memory and prepares them for execution.” It would be more efficient if subroutines could be translated into object form the loader could “relocate” directly behind the user's program. The task of adjusting programs so they may be placed in arbitrary core locations is called relocation. Relocation loaders perform four functions.

1.6 TRANSLATOR

A translator is a program that takes as input a program written in one language and produces as output a program in another language. Besides program translation, the translator performs another very important role, the error-detection. Any violation of the HLL specification would be detected and reported to the programmers. Important roles of translators are:

- 1 Translating the hll program input into an equivalent ml program.
- 2 Providing diagnostic messages wherever the programmer violates specification of the hll.

1.7 TYPE OF TRANSLATORS:-

-  INTERPRETOR
-  COMPILER
-  PREPROSESSOR

1.8 LIST OF COMPILERS

1. Ada compilers
- 2 .ALGOL compilers
- 3 .BASIC compilers
- 4 .C# compilers
- 5 .C compilers
- 6 .C++ compilers
- 7 .COBOL compilers
- 8 .D compilers
- 9 .Common Lisp compilers
10. ECMAScript interpreters
11. Eiffel compilers
12. Felix compilers
13. Fortran compilers
14. Haskell compilers
- 15 .Java compilers
16. Pascal compilers
17. PL/I compilers
18. Python compilers
19. Scheme compilers
20. Smalltalk compilers
21. CIL compilers

1.9 STRUCTURE OF THE COMPILER DESIGN

Phases of a compiler: A compiler operates in phases. A phase is a logically interrelated operation that takes source program in one representation and produces output in another representation. The phases of a compiler are shown in below

There are two phases of compilation.

- a. Analysis (Machine Independent/Language Dependent)
- b. Synthesis(Machine Dependent/Language independent)

Compilation process is partitioned into no-of-sub processes called '**phases**'.

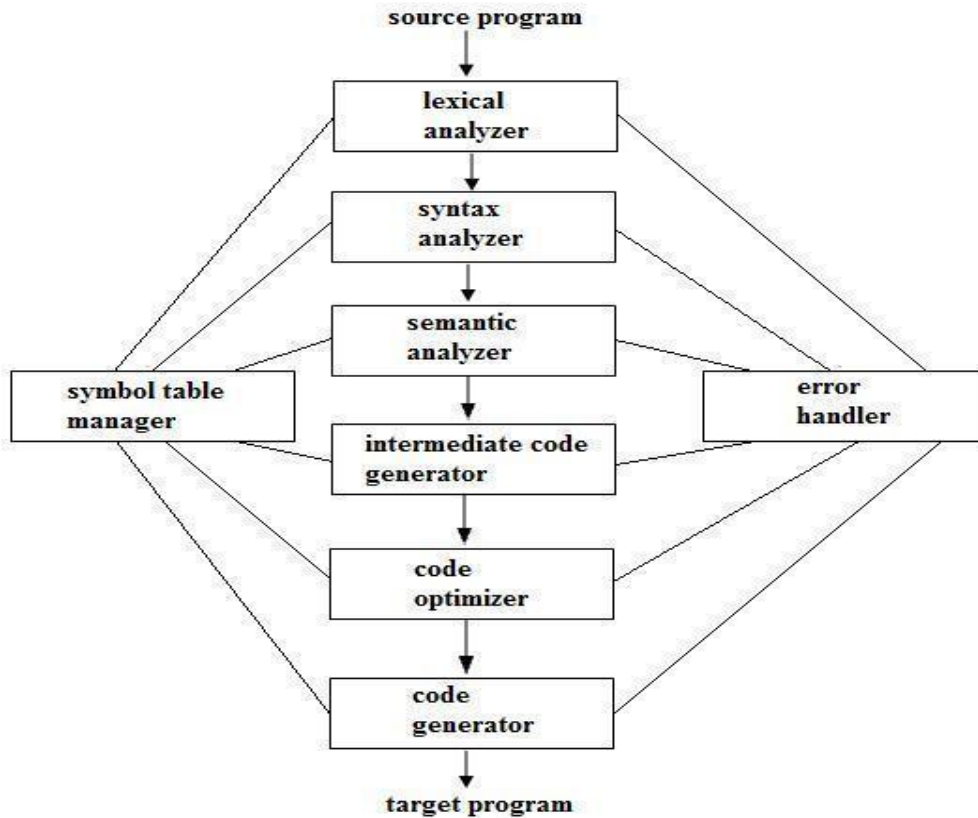

Fig 1.5 Phases of a compiler

Lexical Analysis:-

LA or Scanners reads the source program one character at a time, carving the source program into a sequence of automic units called **tokens**.

Syntax Analysis:-

The second stage of translation is called Syntax analysis or parsing. In this phase expressions, statements, declarations etc... are identified by using the results of lexical analysis. Syntax analysis is aided by using techniques based on formal grammar of the programming language.

Intermediate Code Generations:-

An intermediate representation of the final machine language code is produced. This phase bridges the analysis and synthesis phases of translation.

Code Optimization :-

This is optional phase described to improve the intermediate code so that the output runs faster and takes less space.

Code Generation:-

The last phase of translation is code generation. A number of optimizations to **reduce the length of machine language program** are carried out during this phase. The output of the code generator is the machine language program of the specified computer.

Table Management (or) Book-keeping:-

This is the portion to **keep the names** used by the program and records essential information about each. The data structure used to record this information called a 'Symbol Table'.

Error Handlers:-

It is invoked when a flaw error in the source program is detected.

The output of LA is a stream of tokens, which is passed to the next phase, the syntax analyzer or parser. The SA groups the tokens together into syntactic structure called as **expression**. Expression may further be combined to form statements. The syntactic structure can be regarded as a tree whose leaves are the token called as parse trees.

The parser has two functions. It checks if the tokens from lexical analyzer, occur in pattern that are permitted by the specification for the source language. It also imposes on tokens a tree-like structure that is used by the sub-subsequent phases of the compiler.

Example, if a program contains the expression **A+/B** after lexical analysis this expression might appear to the syntax analyzer as the token sequence **id+/id**. On seeing the /, the syntax analyzer should detect an error situation, because the presence of these two adjacent binary operators violates the formulations rule of an expression.

Syntax analysis is to make explicit the hierarchical structure of the incoming token stream by **identifying which parts of the token stream should be grouped**.

Example, (A/B*C has two possible interpretations.)

- 1, divide A by B and then multiply by C or
- 2, multiply B by C and then use the result to divide A.

each of these two interpretations can be represented in terms of a parse tree.

Intermediate Code Generation:-

The intermediate code generation uses the structure produced by the syntax analyzer to create a stream of simple instructions. Many styles of intermediate code are possible. One common style uses instruction with one operator and a small number of operands.

The output of the syntax analyzer is some representation of a parse tree. the intermediate code generation phase transforms this parse tree into an intermediate language representation of the source program.

Code Optimization

This is optional phase described to improve the intermediate code so that the output runs faster and takes less space. Its output is another intermediate code program that does the some job as the original, but in a way that saves time and / or spaces.

1, Local Optimization:-

There are local transformations that can be applied to a program to make an improvement. For example,

If A > B goto L2

Goto L3

L2 :

This can be replaced by a single statement

If $A < B$ goto L3

Another important local optimization is the elimination of common sub-expressions

 $A := B + C + D$ $E := B + C + F$

Might be evaluated as

 $T1 := B + C$ $A := T1 + D$ $E := T1 + F$ Take this advantage of the common sub-expressions $B + C$.

2, Loop Optimization:-

Another important source of optimization concerns about **increasing the speed of loops**. A typical loop improvement is to move a computation that produces the same result each time around the loop to a point, in the program just before the loop is entered.

Code generator :-

Cg produces the object code by deciding on the memory locations for data, selecting code to access each datum and selecting the registers in which each computation is to be done. Many computers have only a few high speed registers in which computations can be performed quickly. A good code generator would attempt to utilize registers as efficiently as possible.

Table Management OR Book-keeping :-

A compiler needs to collect information about all the data objects that appear in the source program. The information about data objects is collected by the early phases of the compiler-lexical and syntactic analyzers. The data structure used to record this information is called as Symbol Table.

Error Handling :-

One of the most important functions of a compiler is the detection and reporting of errors in the source program. The error message should allow the programmer to determine exactly where the errors have occurred. Errors may occur in all or the phases of a compiler.

Whenever a phase of the compiler discovers an error, it must report the error to the error handler, which issues an appropriate diagnostic msg. Both of the table-management and error-Handling routines interact with all phases of the compiler.

Example:

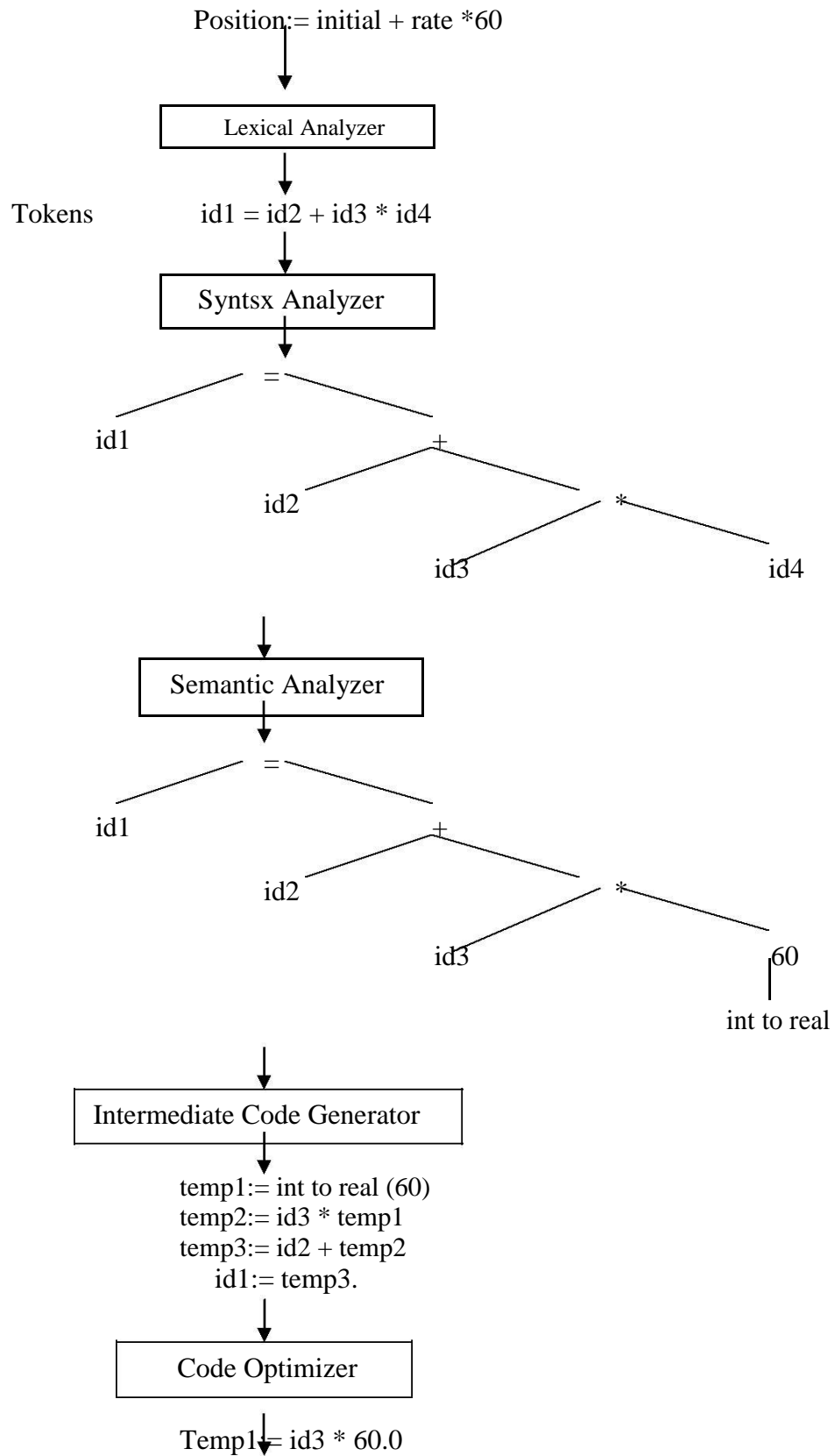

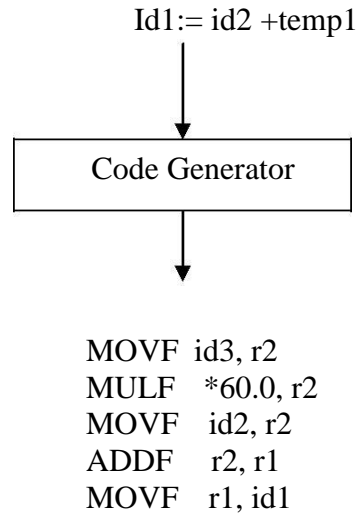

1.10 TOKEN

LA reads the source program one character at a time, carving the source program into a sequence of automatic units called 'Tokens'.

- 1, Type of the token.
- 2, Value of the token.

Type : variable, operator, keyword, constant

Value : Name of variable, current variable (or) pointer to symbol table.

If the symbols given in the standard format the LA accepts and produces token as output. Each token is a sub-string of the program that is to be treated as a single unit. Tokens are two types.

- 1, Specific strings such as IF (or) semicolon.
- 2, Classes of string such as identifiers, label, constants.

UNIT -2

LEXICAL ANALYSIS

2.1 OVER VIEW OF LEXICAL ANALYSIS

- To identify the tokens we need some method of describing the possible tokens that can appear in the input stream. For this purpose we introduce regular expression, a notation that can be used to describe essentially all the tokens of programming language.
- Secondly, having decided what the tokens are, we need some mechanism to recognize these in the input stream. This is done by the token recognizers, which are designed using transition diagrams and finite automata.

2.2 ROLE OF LEXICAL ANALYZER

the LA is the first phase of a compiler. Its main task is to read the input character and produce as output a sequence of tokens that the parser uses for syntax analysis.

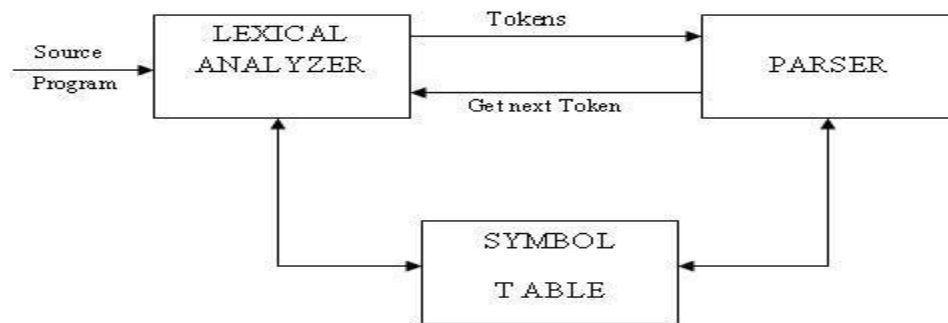

Upon receiving a 'get next token' command from the parser, the lexical analyzer reads the input character until it can identify the next token. The LA returns to the parser representation for the token it has found. The representation will be an integer code, if the token is a simple construct such as parenthesis, comma or colon.

LA may also perform certain secondary tasks as the user interface. One such task is stripping out from the source program the comments and white spaces in the form of blank, tab and new line characters. Another is correlating error message from the compiler with the source program.

2.3 LEXICAL ANALYSIS VS PARSING:

Lexical analysis	Parsing
<p>A Scanner simply turns an input String (say a file) into a list of tokens. These tokens represent things like identifiers, parentheses, operators etc.</p> <p>The lexical analyzer (the "lexer") parses individual symbols from the source code file into tokens. From there, the "parser" proper turns those whole tokens into sentences of your grammar</p>	<p>A parser converts this list of tokens into a Tree-like object to represent how the tokens fit together to form a cohesive whole (sometimes referred to as a sentence).</p> <p>A parser does not give the nodes any meaning beyond structural cohesion. The next thing to do is extract meaning from this structure (sometimes called contextual analysis).</p>

2.4 TOKEN, LEXEME, PATTERN:

Token: Token is a sequence of characters that can be treated as a single logical entity. Typical tokens are,

- 1) Identifiers 2) keywords 3) operators 4) special symbols 5) constants

Pattern: A set of strings in the input for which the same token is produced as output. This set of strings is described by a rule called a pattern associated with the token.

Lexeme: A lexeme is a sequence of characters in the source program that is matched by the pattern for a token.

Example:

Description of token

Token	lexeme	pattern
const	const	const
if	if	If
relation	<, <=, =, >, >=, >	< or <= or = or > or >= or letter followed by letters & digit
i	pi	any numeric constant
nun	3.14	any character b/w "and "except"
literal	"core"	pattern

A pattern is a rule describing the set of lexemes that can represent a particular token in source program.

2.5 LEXICAL ERRORS:

Lexical errors are the errors thrown by your lexer when unable to continue. Which means that there's no way to recognise a *lexeme* as a valid *token* for your lexer. Syntax errors, on the other side, will be thrown by your scanner when a given set of **already** recognised valid tokens don't match any of the right sides of your grammar rules. simple panic-mode error handling system requires that we return to a high-level parsing function when a parsing or lexical error is detected.

Error-recovery actions are:

- i. Delete one character from the remaining input.
- ii. Insert a missing character in to the remaining input.
- iii. Replace a character by another character.
- iv. Transpose two adjacent characters.

2.6 DIFFERENCE BETWEEN COMPILER AND INTERPRETER

A compiler converts the high level instruction into machine language while an interpreter converts the high level instruction into an intermediate form.

Before execution, entire program is executed by the compiler whereas after translating the first line, an interpreter then executes it and so on.

List of errors is created by the compiler after the compilation process while an interpreter stops translating after the first error.

An independent executable file is created by the compiler whereas interpreter is required by an interpreted program each time.

The compiler produce object code whereas interpreter does not produce object code.

In the process of compilation the program is analyzed only once and then the code is generated whereas source program is interpreted every time it is to be executed and every time the source program is analyzed. hence interpreter is less efficient than compiler.

Examples of interpreter: A *UPS Debugger* is basically a graphical source level debugger but it contains built in C interpreter which can handle multiple source files.

example of compiler: *Borland c compiler* or Turbo C compiler compiles the programs written in C or C++.

2.7 REGULAR EXPRESSIONS

Regular expression is a formula that describes a possible set of string.

Component of regular expression..

X	the character x
.	any character, usually accept a new line
[x y z]	any of the characters x, y, z,
R?	a R or nothing (=optionally as R)
R*	zero or more occurrences.....
R+	one or more occurrences
R1R2	an R1 followed by an R2
R2R1	either an R1 or an R2.

A token is either a single string or one of a collection of strings of a certain type. If we view the set of strings in each token class as an language, we can use the regular-expression notation to describe tokens.

Consider an identifier, which is defined to be a letter followed by zero or more letters or digits. In regular expression notation we would write.

Identifier = letter (letter | digit)*

Here are the rules that define the regular expression over alphabet .

- is a regular expression denoting { ϵ }, that is, the language containing only the empty string.
- For each 'a' in Σ , is a regular expression denoting { a }, the language with only one string consisting of the single symbol 'a' .
- If R and S are regular expressions, then

(R) | (S) means $L_r \cup L_s$
 R.S means $L_r.L_s$
 R* denotes L_r^*

2.8 REGULAR DEFINITIONS

For notational convenience, we may wish to give names to regular expressions and to define regular expressions using these names as if they were symbols.

Identifiers are the set or string of letters and digits beginning with a letter. The following regular definition provides a precise specification for this class of string.

Example-1,

$Ab^*|cd?$ Is equivalent to $(a(b^*)) | (c(d?))$

Pascal identifier

Letter - A | B | | Z | a | b | | z |

Digits - 0 | 1 | 2 | | 9

letter (letter / digit)*

I
d

-

Recognition of tokens:

We learn how to express pattern using regular expressions. Now, we must study how to take the patterns for all the needed tokens and build a piece of code that examines the input string and finds a prefix that is a lexeme matching one of the patterns.

```

    Stmt  → if expr then stmt
          | If expr then else stmt
          | ε
    Expr  → term relop term |
          term
    Term  → id
          |number
    
```

For relop ,we use the comparison operations of languages like Pascal or SQL where = is “equals” and <> is “not equals” because it presents an interesting structure of lexemes. The terminal of grammar, which are if, then , else, relop ,id and numbers are the names of tokens as far as the lexical analyzer is concerned, the patterns for the tokens are described using regular definitions.

```

digit    -->[0,9]
digits   -->digit+
number   -->digit(.digit)?(e.[+-]?digits)?
letter   -->[A-Z,a-z]
id       -->letter(letter/digit)*
if       --> if
then     -->then
else     -->else
relop    --></><=>/=//< >
    
```

In addition, we assign the lexical analyzer the job stripping out white space, by recognizing the “token” we defined by:

```

ws → (blank/tab/newline)+
    
```

Here, blank, tab and newline are abstract symbols that we use to express the ASCII characters of the same names. Token ws is different from the other tokens in that ,when we recognize it, we do not return it to parser ,but rather restart the lexical analysis from the character that follows the white space . It is the following token that gets returned to the parser.

Lexeme	Token Name	Attribute Value
Any ws	_	_
if	if	_
then	then	_
else	else	_
Any id	id	pointer to table entry
Any number	number	pointer to table entry
<	relop	LT

<=	relop	LE
=	relop	ET
<>	relop	NE

2.9 TRANSITION DIAGRAM:

Transition Diagram has a collection of nodes or circles, called states. Each state represents a condition that could occur during the process of scanning the input looking for a lexeme that matches one of several patterns .

Edges are directed from one state of the transition diagram to another. each edge is labeled by a symbol or set of symbols.

If we are in one state s, and the next input symbol is a, we look for an edge out of state s labeled by a. if we find such an edge ,we advance the forward pointer and enter the state of the transition diagram to which that edge leads.

Some important conventions about transition diagrams are

1. Certain states are said to be accepting or final .These states indicates that a lexeme has been found, although the actual lexeme may not consist of all positions b/w the lexeme Begin and forward pointers we always indicate an accepting state by a double circle.
2. In addition, if it is necessary to return the forward pointer one position, then we shall additionally place a * near that accepting state.
3. One state is designed the state ,or initial state , it is indicated by an edge labeled “start” entering from nowhere .the transition diagram always begins in the state before any input symbols have been used.

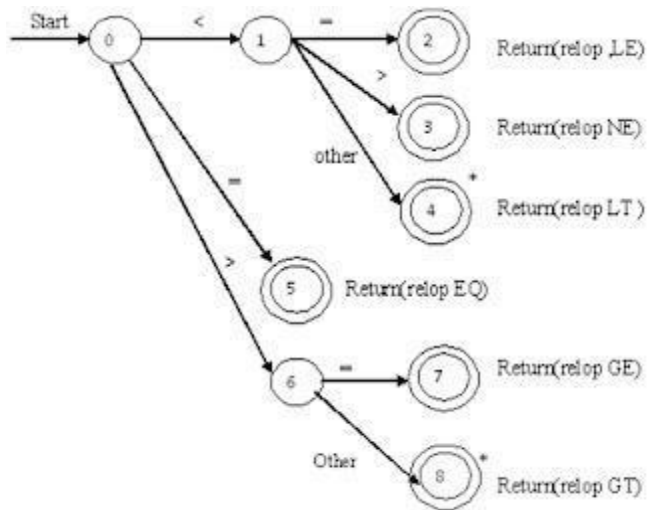

As an intermediate step in the construction of a LA, we first produce a stylized flowchart, called a transition diagram. Position in a transition diagram, are drawn as circles and are called as states.

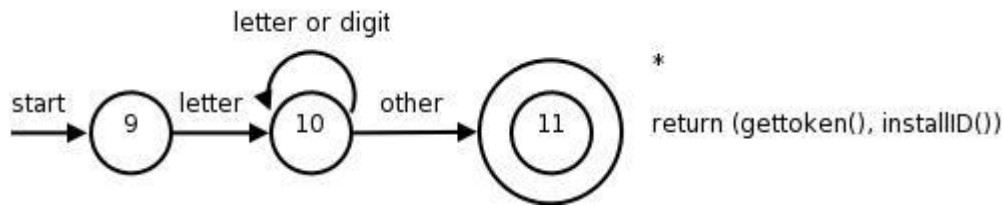

The above TD for an identifier, defined to be a letter followed by any no of letters or digits. A sequence of transition diagram can be converted into program to look for the tokens specified by the diagrams. Each state gets a segment of code.

If	=	if
Then	=	then
Else	=	else
Relop	=	< <= = > >=
Id	=	letter (letter digit) *
Num	=	digit

2.10 AUTOMATA

An automation is defined as a system where information is transmitted and used for performing some functions without direct participation of man.

- 1, an automation in which the output depends only on the input is **called an automation without memory.**
- 2, an automation in which the output depends on the input and state also is **called as automation with memory.**
- 3, an automation in which the output depends only on the state of the machine is **called a Moore machine.**
- 3, an automation in which the output depends on the state and input at any instant of time is **called a mealy machine.**

2.11 DESCRIPTION OF AUTOMATA

- 1, an automata has a mechanism to read input from input tape,
- 2, any language is recognized by some automation, Hence these automation are basically language ‘acceptors’ or ‘language recognizers’.

Types of Finite Automata

- | Deterministic Automata
- | Non-Deterministic Automata.

2.12 DETERMINISTIC AUTOMATA

A deterministic finite automata has at most one transition from each state on any input. A DFA is a special case of a NFA in which:-

- 1, it has no transitions on input ϵ ,

2, each input symbol has at most one transition from any state.

DFA formally defined by 5 tuple notation $M = (Q, \Sigma, \delta, q_0, F)$, where

Q is a finite 'set of states', which is non empty.

Σ is 'input alphabets', indicates input set.

q_0 is an 'initial state' and q_0 is in Q ie, q_0, Σ, Q

F is a set of 'Final states',

δ is a 'transmission function' or mapping function, using this function the next state can be determined.

The regular expression is converted into minimized DFA by the following procedure:

Regular expression \rightarrow NFA \rightarrow DFA \rightarrow Minimized DFA

The Finite Automata is called DFA if there is only one path for a specific input from current state to next state.

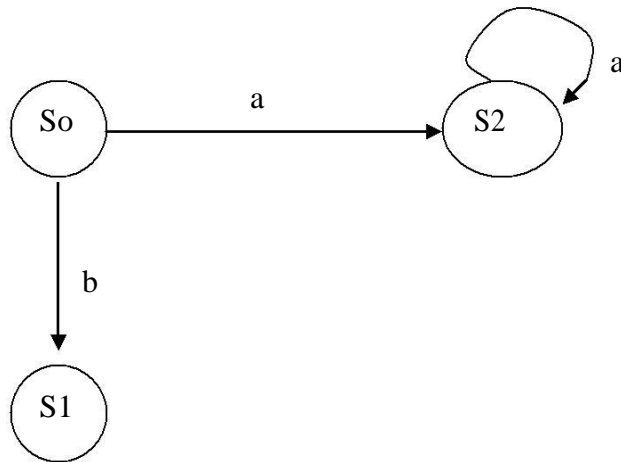

From state S_0 for input 'a' there is only one path going to S_2 . similarly from S_0 there is only one path for input going to S_1 .

2.13 NONDETERMINISTIC AUTOMATA

✚ A NFA is a mathematical model that consists of

- A set of states S .
- A set of input symbols Σ .
- A transition for move from one state to an other.
- A state q_0 that is distinguished as the start (or initial) state.
- A set of states F distinguished as accepting (or final) state.
- A number of transition to a single symbol.

- ✦ A NFA can be diagrammatically represented by a labeled directed graph, called a transition graph, In which the nodes are the states and the labeled edges represent the transition function.
- ✦ This graph looks like a transition diagram, but the same character can label two or more transitions out of one state and edges can be labeled by the special symbol ϵ as well as by input symbols.
- ✦ The transition graph for an NFA that recognizes the language $(a | b) ^ * abb$ is shown

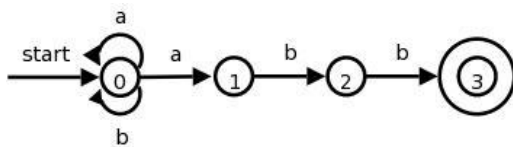

2.14 DEFINITION OF CFG

It involves four quantities.

CFG contain terminals, N-T, start symbol and production.

- ✦ Terminal are basic symbols form which string are formed.
- ✦ N-terminals are synthetic variables that denote sets of strings
- ✦ In a Grammar, one N-T are distinguished as the start symbol, and the set of string it denotes is the language defined by the grammar.
- ✦ The production of the grammar specify the manor in which the terminal and N-T can be combined to form strings.
- ✦ Each production consists of a N-T, followed by an arrow, followed by a string of one terminal and terminals.

2.15 DEFINITION OF SYMBOL TABLE

- ✦ An extensible array of records.
- ✦ The identifier and the associated records contains collected information about the identifier.
 FUNCTION identify (Identifier name)
 RETURNING a pointer to identifier information contains
- ✦ The actual string
- ✦ A macro definition A
- ✦ keyword definition
- ✦ A list of type, variable & function definition
- ✦ A list of structure and union name definition
- ✦ A list of structure and union field selected definitions.

2.16 Creating a lexical analyzer with Lex

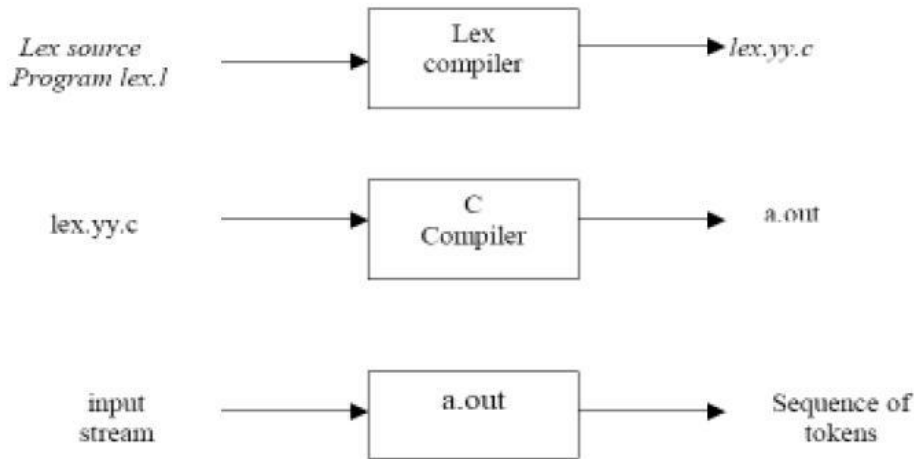

2.17 Lex specifications:

A Lex program (the .l file) consists of three parts:

declarations

%%

translation rules

%%

auxiliary procedures

1. The *declarations* section includes declarations of variables, manifest constants (A manifest constant is an identifier that is declared to represent a constant e.g. # define PIE 3.14), and regular definitions.
2. The *translation rules* of a Lex program are statements of the form :

```

p1          {action 1}
p2          {action 2}
p3          {action 3}
...         ...
...         ...
  
```

where each *p* is a regular expression and each *action* is a program fragment describing what action the lexical analyzer should take when a pattern *p* matches a lexeme. In Lex the actions are written in C.

3. The third section holds whatever *auxiliary procedures* are needed by the *actions*. Alternatively these procedures can be compiled separately and loaded with the lexical analyzer.

Note: You can refer to a sample lex program given in page no. 109 of chapter 3 of the book: *Compilers: Principles, Techniques, and Tools* by Aho, Sethi & Ullman for more clarity.

2.18 INPUT BUFFERING

The LA scans the characters of the source pgm one at a time to discover tokens. Because of large amount of time can be consumed scanning characters, specialized buffering techniques have been developed to reduce the amount of overhead required to process an input character.

Buffering techniques:

1. Buffer pairs
2. Sentinels

The lexical analyzer scans the characters of the source program one at a time to discover tokens. Often, however, many characters beyond the next token many have to be examined before the next token itself can be determined. For this and other reasons, it is desirable for the lexical analyzer to read its input from an input buffer. Figure shows a buffer divided into two halves of, say 100 characters each. One pointer marks the beginning of the token being discovered. A look ahead pointer scans ahead of the beginning point, until the token is discovered. We view the position of each pointer as being between the character last read and the character next to be read. In practice each buffering scheme adopts one convention either a pointer is at the symbol last read or the symbol it is ready to read.

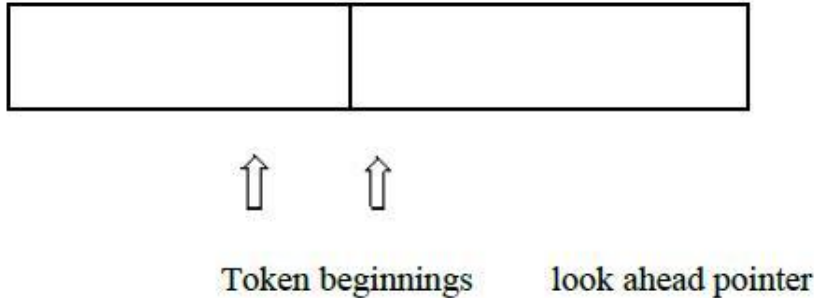

Token beginnings look ahead pointer The distance which the lookahead pointer may have to travel past the actual token may be large. For example, in a PL/I program we may see: `DECLARE (ARG1, ARG2... ARG n)` Without knowing whether `DECLARE` is a keyword or an array name until we see the character that follows the right parenthesis. In either case, the token itself ends at the second `E`. If the look ahead pointer travels beyond the buffer half in which it began, the other half must be loaded with the next characters from the source file. Since the buffer shown in above figure is of limited size there is an implied constraint on how much look ahead can be used before the next token is discovered. In the above example, if the look ahead traveled to the left half and all the way through the left half to the middle, we could not reload the right half, because we would lose characters that had not yet been grouped into tokens. While we can make the buffer larger if we chose or use another buffering scheme, we cannot ignore the fact that overhead is limited.

UNIT -3

SYNTAX ANALYSIS

3.1 ROLE OF THE PARSER

Parser obtains a string of tokens from the lexical analyzer and verifies that it can be generated by the language for the source program. The parser should report any syntax errors in an intelligible fashion. The two types of parsers employed are:

1. Top down parser: which build parse trees from top(root) to bottom(leaves)
2. Bottom up parser: which build parse trees from leaves and work up the root.

Therefore there are two types of parsing methods– top-down parsing and bottom-up parsing

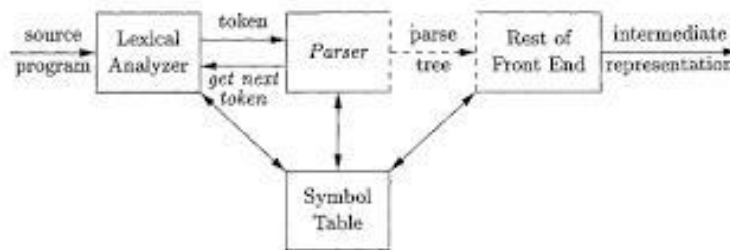

Figure 4.1: Position of parser in compiler model

3.2 TOP-DOWN PARSING

A program that performs syntax analysis is called a parser. A syntax analyzer takes tokens as input and output error message if the program syntax is wrong. The parser uses symbol-look-ahead and an approach called top-down parsing without backtracking. Top-down parsers check to see if a string can be generated by a grammar by creating a parse tree starting from the initial symbol and working down. Bottom-up parsers, however, check to see a string can be generated from a grammar by creating a parse tree from the leaves, and working up. Early parser generators such as YACC creates bottom-up parsers whereas many of Java parser generators such as JavaCC create top-down parsers.

3.3 RECURSIVE DESCENT PARSING

Typically, top-down parsers are implemented as a set of recursive functions that descent through a parse tree for a string. This approach is known as recursive descent parsing, also known as LL(k) parsing where the first L stands for left-to-right, the second L stands for

JBIET

leftmost-derivation, and k indicates k -symbol lookahead. Therefore, a parser using the single symbol look-ahead method and top-down parsing without backtracking is called LL(1) parser. In the following sections, we will also use an extended BNF notation in which some regulation expression operators are to be incorporated.

A syntax expression defines sentences of the form S , or $S_1 S_2$. A syntax of the form $S_1 S_2$ defines sentences that consist of a sentence of the form S_1 followed by a sentence of the form S_2 . A syntax of the form S_1^* defines zero or one occurrence of the form S_1 . A syntax of the form S_1^+ defines zero or more occurrences of the form S_1 .

A usual implementation of an LL(1) parser is:

- initialize its data structures,
- get the lookahead token by calling scanner routines, and
- call the routine that implements the start symbol.

Here is an example.

```
proc syntaxAnalysis()  
begin  
  
  initialize(); // initialize global data and structures  
  nextToken(); // get the lookahead token  
  
  program(); // parser routine that implements the start  
  symbol end;
```

3.4 FIRST AND FOLLOW

To compute FIRST(X) for all grammar symbols X , apply the following rules until no more terminals or ϵ can be added to any FIRST set.

1. If X is terminal, then FIRST(X) is $\{X\}$.
2. If $X \rightarrow \epsilon$ is a production, then add ϵ to FIRST(X).
3. If X is nonterminal and $X \rightarrow Y_1 Y_2 \dots Y_k$ is a production, then place a in FIRST(X) if for some i , a is in FIRST(Y_i) and ϵ is in all of FIRST(Y_1), ..., FIRST(Y_{i-1}) that is, $Y_1 \dots Y_{i-1} \Rightarrow^* \epsilon$. If ϵ is in FIRST(Y_j) for all $j=1, 2, \dots, k$, then add ϵ to FIRST(X). For

example, everything in FIRST(Y_j) is surely in FIRST(X). If Y_1 does not derive ϵ , then we add nothing more to FIRST(X), but if $Y_1 \Rightarrow^* \epsilon$, then we add FIRST(Y_2) and so on.

JBLET

To compute the $FIRST(A)$ for all nonterminals A , apply the following rules until nothing can be added to any FOLLOW set.

1. Place $\$$ in $FOLLOW(S)$, where S is the start symbol and $\$$ is the input right endmarker.
2. If there is a production $A \Rightarrow aBs$ where $FIRST(s)$ except ϵ is placed in $FOLLOW(B)$.
3. If there is a production $A \rightarrow aB$ or a production $A \rightarrow aBs$ where $FIRST(s)$ contains ϵ , then everything in $FOLLOW(A)$ is in $FOLLOW(B)$.

Consider the following example to understand the concept of First and Follow. Find the first and follow of all nonterminals in the Grammar-

$E \rightarrow TE'$

$E' \rightarrow +TE'|e$

$T \rightarrow FT'$

$T' \rightarrow *FT'|e$

$F \rightarrow (E)|id$

Then:

$FIRST(E) = FIRST(T) = FIRST(F) = \{ (, id \}$

$FIRST(E') = \{ +, e \}$

$FIRST(T') = \{ *, e \}$

$FOLLOW(E) = FOLLOW(E') = \{), \$ \}$

$FOLLOW(T) = FOLLOW(T') = \{ +,), \$ \}$

$FOLLOW(F) = \{ +, *,), \$ \}$

For example, id and left parenthesis are added to $FIRST(F)$ by rule 3 in definition of $FIRST$ with $i=1$ in each case, since $FIRST(id) = (id)$ and $FIRST('(') = \{ (\}$ by rule 1. Then by rule 3 with $i=1$, the production $T \rightarrow FT'$ implies that id and left parenthesis belong to $FIRST(T)$ also.

To compute FOLLOW, we put $\$$ in $FOLLOW(E)$ by rule 1 for FOLLOW. By rule 2 applied to production $F \rightarrow (E)$, right parenthesis is also in $FOLLOW(E)$. By rule 3 applied to production $E \rightarrow TE'$, $\$$ and right parenthesis are in $FOLLOW(E')$.

3.5 CONSTRUCTION OF PREDICTIVE PARSING TABLES

For any grammar G, the following algorithm can be used to construct the predictive parsing table. The algorithm is

Input : Grammar G

Output : Parsing table M

Method

1. For each production $A \rightarrow a$ of the grammar, do steps 2 and 3.
2. For each terminal a in $FIRST(a)$, add $A \rightarrow a$, to $M[A,a]$.
3. If ϵ is in $FIRST(a)$, add $A \rightarrow a$ to $M[A,b]$ for each terminal b in $FOLLOW(A)$. If ϵ is in $FIRST(a)$ and $\$$ is in $FOLLOW(A)$, add $A \rightarrow a$ to $M[A,\$]$.
4. Make each undefined entry of M be error.

3.6.LL(1) GRAMMAR

The above algorithm can be applied to any grammar G to produce a parsing table M. For some Grammars, for example if G is left recursive or ambiguous, then M will have at least one multiply-defined entry. A grammar whose parsing table has no multiply defined entries is said to be LL(1). It can be shown that the above algorithm can be used to produce for every LL(1) grammar G a parsing table M that parses all and only the sentences of G. LL(1) grammars have several distinctive properties. No ambiguous or left recursive grammar can be LL(1). There remains a question of what should be done in case of multiply defined entries. One easy solution is to eliminate all left recursion and left factoring, hoping to produce a grammar which will produce no multiply defined entries in the parse tables. Unfortunately there are some grammars which will give an LL(1) grammar after any kind of alteration. In general, there are no universal rules to convert multiply defined entries into single valued entries without affecting the language recognized by the parser.

The main difficulty in using predictive parsing is in writing a grammar for the source language such that a predictive parser can be constructed from the grammar. Although left recursion elimination and left factoring are easy to do, they make the resulting grammar hard to read and difficult to use the translation purposes. To alleviate some of this difficulty, a common organization for a parser in a compiler is to use a predictive parser for control

constructs and to use operator precedence for expressions. However, if an LR parser generator is available, one can get all the benefits of predictive parsing and operator precedence automatically.

3.7.ERROR RECOVERY IN PREDICTIVE PARSING

The stack of a nonrecursive predictive parser makes explicit the terminals and nonterminals that the parser hopes to match with the remainder of the input. We shall therefore refer to symbols on the parser stack in the following discussion. An error is detected during predictive parsing when the terminal on top of the stack does not match the next input symbol or when nonterminal A is on top of the stack, a is the next input symbol, and the parsing table entry $M[A,a]$ is empty.

Panic-mode error recovery is based on the idea of skipping symbols on the input until a token in a selected set of synchronizing tokens appears. Its effectiveness depends on the choice of synchronizing set. The sets should be chosen so that the parser recovers quickly from errors that are likely to occur in practice. Some heuristics are as follows

- ✦ As a starting point, we can place all symbols in $FOLLOW(A)$ into the synchronizing set for nonterminal A . If we skip tokens until an element of $FOLLOW(A)$ is seen and pop A from the stack, it is likely that parsing can continue.
- ✦ It is not enough to use $FOLLOW(A)$ as the synchronizing set for A . For example, if semicolons terminate statements, as in C, then keywords that begin statements may not appear in the $FOLLOW$ set of the nonterminal generating expressions. A missing semicolon after an assignment may therefore result in the keyword beginning the next statement being skipped. Often, there is a hierarchical structure on constructs in a language; e.g., expressions appear within statements, which appear within blocks, and so on. We can add to the synchronizing set of a lower construct the symbols that begin higher constructs. For example, we might add keywords that begin statements to the synchronizing sets for the nonterminals generating expressions.
- ✦ If we add symbols in $FIRST(A)$ to the synchronizing set for nonterminal A , then it may be possible to resume parsing according to A if a symbol in $FIRST(A)$ appears in the input.

JBIET

- ✦ If a nonterminal can generate the empty string, then the production deriving ϵ can be used as a default. Doing so may postpone some error detection, but cannot cause an error to be missed. This approach reduces the number of nonterminals that have to be considered during error recovery.
- ✦ If a terminal on top of the stack cannot be matched, a simple idea is to pop the terminal, issue a message saying that the terminal was inserted, and continue parsing. In effect, this approach takes the synchronizing set of a token to consist of all other tokens.

UNIT 4

LR PARSER

4.1 LR PARSING INTRODUCTION

The "L" is for left-to-right scanning of the input and the "R" is for constructing a rightmost derivation in reverse.

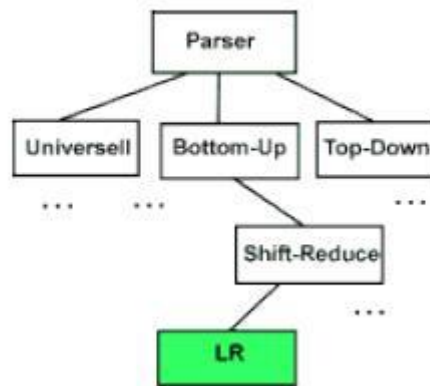

4.2 WHY LR PARSING:

- ✓ LR parsers can be constructed to recognize virtually all programming-language constructs for which context-free grammars can be written.
- ✓ The LR parsing method is the most general non-backtracking shift-reduce parsing method known, yet it can be implemented as efficiently as other shift-reduce methods.
- ✓ The class of grammars that can be parsed using LR methods is a proper subset of the class of grammars that can be parsed with predictive parsers.
- ✓ An LR parser can detect a syntactic error as soon as it is possible to do so on a left-to-right scan of the input.

The disadvantage is that it takes too much work to construct an LR parser by hand for a typical programming-language grammar. But there are lots of LR parser generators available to make this task easy.

4.3.MODELS OF LR PARSERS

The schematic form of an LR parser is shown below.

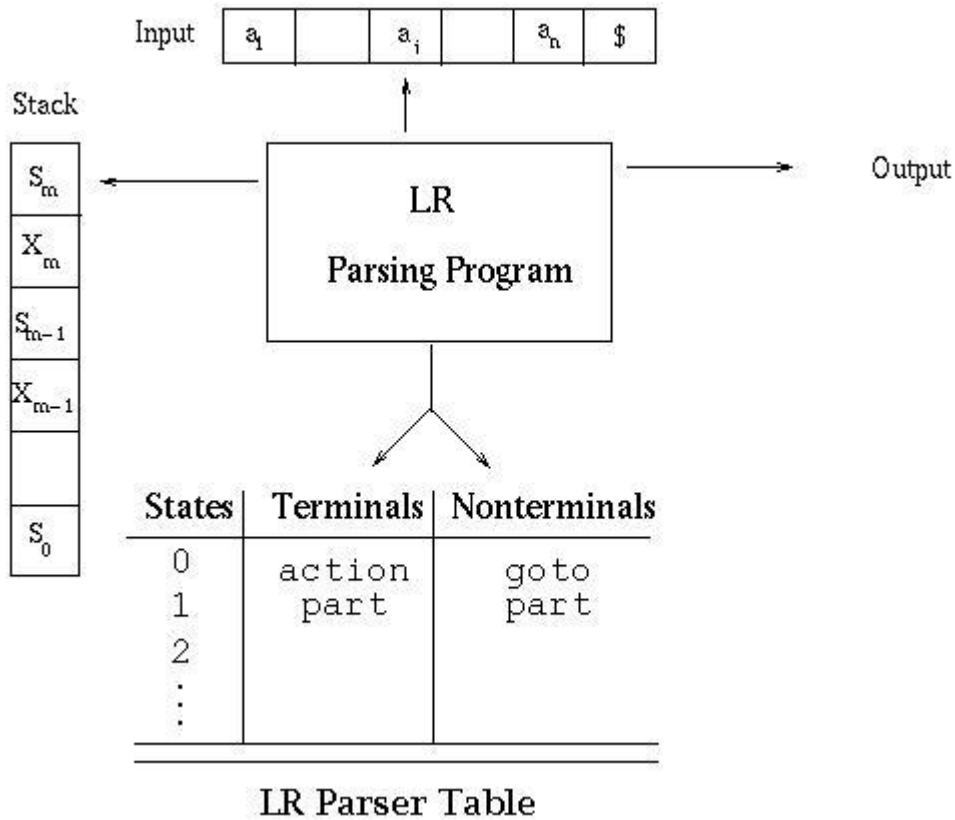

The program uses a stack to store a string of the form $s_0X_1s_1X_2...X_ms_m$ where s_m is on top. Each X_i is a grammar symbol and each s_i is a symbol representing a state. Each state symbol summarizes the information contained in the stack below it. The combination of the state symbol on top of the stack and the current input symbol are used to index the parsing table and determine the shift/reduce parsing decision. The parsing table consists of two parts: a parsing action function action and a goto function goto. The program driving the LR parser behaves as follows: It determines s_m the state currently on top of the stack and a_i the current input symbol. It then consults $action[s_m, a_i]$, which can have one of four values:

- shift s , where s is a state
- reduce by a grammar production $A \rightarrow b$
- accept
- error

JBLET

The function goto takes a state and grammar symbol as arguments and produces a state.

For a parsing table constructed for a grammar G, the goto table is the transition function of a deterministic finite automaton that recognizes the viable prefixes of G. Recall that the viable prefixes of G are those prefixes of right-sentential forms that can appear on the stack of a shiftreduce parser because they do not extend past the rightmost handle.

A configuration of an LR parser is a pair whose first component is the stack contents and whose second component is the unexpanded input:

$(s_0 X_1 s_1 X_2 s_2 \dots X_m s_m, a_i a_{i+1} \dots a_n \$)$

This configuration represents the right-sentential form $X_1 X_1 \dots X_m a_i a_{i+1} \dots a_n$

in essentially the same way a shift-reduce parser would; only the presence of the states on the stack is new. Recall the sample parse we did (see Example 1: Sample bottom-up parse) in which we assembled the right-sentential form by concatenating the remainder of the input buffer to the top of the stack. The next move of the parser is determined by reading a_i and s_m , and consulting the parsing action table entry $\text{action}[s_m, a_i]$. Note that we are just looking at the state here and no symbol below it. We'll see how this actually works later.

The configurations resulting after each of the four types of move are as follows:

If $\text{action}[s_m, a_i] = \text{shift } s$, the parser executes a shift move entering the configuration $(s_0 X_1 s_1 X_2 s_2 \dots X_m s_m a_i s, a_{i+1} \dots a_n \$)$

Here the parser has shifted both the current input symbol a_i and the next symbol.

If $\text{action}[s_m, a_i] = \text{reduce } A \rightarrow b$, then the parser executes a reduce move, entering the configuration,

$(s_0 X_1 s_1 X_2 s_2 \dots X_{m-r} s_{m-r} A s, a_i a_{i+1} \dots a_n \$)$

where $s = \text{goto}[s_{m-r}, A]$ and r is the length of b , the right side of the production. The parser first popped $2r$ symbols off the stack (r state symbols and r grammar symbols), exposing state s_{m-r} . The parser then pushed both A , the left side of the production, and s , the entry for $\text{goto}[s_{m-r}, A]$, onto the stack. The current input symbol is not changed in a reduce move.

The output of an LR parser is generated after a reduce move by executing the semantic action associated with the reducing production. For example, we might just print out the production reduced.

If $\text{action}[s_m, a_i] = \text{accept}$, parsing is completed.

4.4. OPERATOR PRECEDENCE PARSING

Precedence Relations

Bottom-up parsers for a large class of context-free grammars can be easily developed using operator grammars. Operator grammars have the property that no production right side is empty or has two adjacent nonterminals. This property enables the implementation of efficient operator-precedence parsers. These parsers rely on the following three precedence relations:

Relation Meaning

$a < \cdot b$ yields precedence to b

$a = \cdot b$ has the same precedence as b

$a \cdot > b$ takes precedence over b

These operator precedence relations allow to delimit the handles in the right sentential forms:

$< \cdot$ marks the left end, $= \cdot$ appears in the interior of the handle, and $\cdot >$ marks the right end.

	id	+	*	\$
id		$\cdot >$	$\cdot >$	$\cdot >$
+	$< \cdot$	$\cdot >$	$< \cdot$	$\cdot >$
*	$< \cdot$	$\cdot >$	$\cdot >$	$\cdot >$
\$	$< \cdot$	$< \cdot$	$< \cdot$	$\cdot >$

Example: The input string:

id1 + id2 * id3

after inserting precedence relations becomes

$\$ < \cdot \text{id1} \cdot > + < \cdot \text{id2} \cdot > * < \cdot \text{id3} \cdot > \$$

Having precedence relations allows to identify handles as follows:

- scan the string from left until seeing $\cdot >$
- scan backwards the string from right to left until seeing $< \cdot$
- everything between the two relations $< \cdot$ and $\cdot >$ forms the handle

4.5 OPERATOR PRECEDENCE PARSING ALGORITHM

Initialize: Set ip to point to the first symbol of w\$

*Repeat: Let X be the top stack symbol, and a the symbol pointed to by ip
if \$ is on the top of the stack and ip points to \$ then return*

else

*Let a be the top terminal on the stack, and b the symbol pointed to
by ip*

if $a < \cdot b$ or $a = \cdot b$ then

push b onto the stack

advance ip to the next input symbol

else if $a \cdot > b$ then

repeat

pop the stack

until the top stack terminal is related by $< \cdot$

to the terminal most recently popped

else error()

end

4.6 ALGORITHM FOR CONSTRUCTING PRECEDENCE FUNCTIONS

1. Create functions f_a for each grammar terminal a and for the end of string symbol;
2. Partition the symbols in groups so that f_a and f_b are in the same group if $a = \cdot b$ (there can be symbols in the same group even if they are not connected by this relation)
3. Create a directed graph whose nodes are in the groups, next for each symbols a and b
do: place an edge from the group of f_b to the group of f_a if $a < \cdot b$, otherwise if $a \cdot > b$
place an edge from the group of f_a to that of f_b ;
4. If the constructed graph has a cycle then no precedence functions exist. When there are no cycles collect the length of the longest paths from the groups of f_a and f_b Example:

	id	+	*	\$
id		.>	.>	.>
+	<.	.>	<.	.>
*	<.	.>	.>	.>
\$	<.	<.	<.	.>

Consider the above table Using the algorithm leads to the following graph:

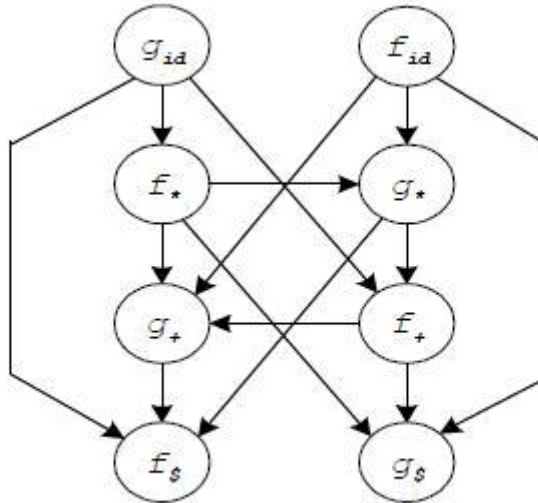

4.7 SHIFT REDUCE PARSING

A shift-reduce parser uses a parse stack which (conceptually) contains grammar symbols. During the operation of the parser, symbols from the input are shifted onto the stack. If a prefix of the symbols on top of the stack matches the RHS of a grammar rule which is the correct rule to use within the current context, then the parser reduces the RHS of the rule to its LHS, replacing the RHS symbols on top of the stack with the nonterminal occurring on the LHS of the rule. This shift-reduce process continues until the parser terminates, reporting either success or failure. It terminates with success when the input is legal and is accepted by the parser. It terminates with failure if an error is detected in the input. The parser is nothing but a stack automaton which may be in one of several discrete states. A state is usually represented simply as an integer. In reality, the parse stack contains states, rather than

grammar symbols. However, since each state corresponds to a unique grammar symbol, the state stack can be mapped onto the grammar symbol stack mentioned earlier.

The operation of the parser is controlled by a couple of tables:

4.8 ACTION TABLE

The action table is a table with rows indexed by states and columns indexed by terminal symbols. When the parser is in some state s and the current lookahead terminal is t , the action taken by the parser depends on the contents of $\text{action}[s][t]$, which can contain four different kinds of entries:

Shift s'

Shift state s' onto the parse

stack. Reduce r

Reduce by rule r . This is explained in more detail below.

Accept

Terminate the parse with success, accepting the input. Error

Signal a parse error

4.9 GOTO TABLE

The goto table is a table with rows indexed by states and columns indexed by nonterminal symbols. When the parser is in state s immediately after reducing by rule N , then the next state to enter is given by $\text{goto}[s][N]$.

The current state of a shift-reduce parser is the state on top of the state stack. The detailed operation of such a parser is as follows:

1. Initialize the parse stack to contain a single state s_0 , where s_0 is the distinguished initial state of the parser.
2. Use the state s on top of the parse stack and the current lookahead t to consult the action table entry $\text{action}[s][t]$:
 - If the action table entry is shift s' then push state s' onto the stack and advance the input so that the lookahead is set to the next token.
 - If the action table entry is reduce r and rule r has m symbols in its RHS, then pop m symbols off the parse stack. Let s' be the state now revealed on top of the parse stack and N be the LHS nonterminal for rule r . Then consult the goto table and

push the state given by goto[s][N] onto the stack. The lookahead token is not changed by this step.

- If the action table entry is accept, then terminate the parse with success.
- If the action table entry is error, then signal an error.

3. Repeat step (2) until the parser terminates.

For example, consider the following simple grammar

0) $\$S$: stmt <EOF>

1) stmt: ID ':=' expr

2) expr: expr '+' ID

3) expr: expr '-' ID

4) expr: ID

which describes assignment statements like $a := b + c - d$. (Rule 0 is a special augmenting production added to the grammar).

One possible set of shift-reduce parsing tables is shown below (sn denotes shift n, rn denotes reduce n, acc denotes accept and blank entries denote error entries):

Parser Tables

Parser Tables

	Action Table					Goto Table	
	ID	':='	'+'	'-'	<EOF>	stmt	expr
0	s1					g2	
1		s3					
2					s4		
3	s5	r					g6
4	acc	acc	acc	acc	acc		
5	r4	r4	r4	r4	r4		
6	r1	r1	s7	s8	r1		
7	s9						
8	s10						
9	r2	r2	r2	r2	r2		
10	r3	r3	r3	r3	r3		

A trace of the parser on the input $a := b + c - d$ is shown below:

Stack	Remaining Input	Action
0/\$\$	$a := b + c - d$	s1
0/\$\$ 1/a	$:= b + c - d$	s3
0/\$\$ 1/a 3/	$:= b + c - d$	s5
0/\$\$ 1/a 3/ = 5/	$b + c - d$	r4
0/\$\$ 1/a 3/ = +	$c - d$	g6 on expr
0/\$\$ 1/a 3/ = 6/expr	$+ c - d$	s7
0/\$\$ 1/a 3/ = 6/expr 7/	$+ c - d$	s9
0/\$\$ 1/a 3/ = 6/expr 7/ + 9/	$c - d$	r2
0/\$\$ 1/a 3/ = -	d	g6 on expr
0/\$\$ 1/a 3/ = 6/expr	$- d$	s8
0/\$\$ 1/a 3/ = 6/expr 8/	$- d$	s10
0/\$\$ 1/a 3/ = 6/expr 8/ - 10/	$<EOF>$	r3
0/\$\$ 1/a 3/ =	$<EOF>$	g6 on expr
0/\$\$ 1/a 3/ = 6/expr	$<EOF>$	r1
0/\$\$	$<EOF>$	g2 on stmt
0/\$\$ 2/stmt	$<EOF>$	s4
0/\$\$ 2/stmt 4/	$<EOF>$	accept

Each stack entry is shown as a state number followed by the symbol which caused the transition to that state.

4.10 SLR PARSER

An $LR(0)$ item (or just *item*) of a grammar G is a production of G with a dot at some position of the right side indicating how much of a production we have seen up to a given point.

For example, for the production $E \rightarrow E + T$ we would have the following items:

$[E \rightarrow .E + T]$

$[E \rightarrow E. + T]$

$[E \rightarrow E + .T]$

$[E \rightarrow E + T.]$

Stack	State	Comments
Empty	$[E' \rightarrow .E]$	can't go anywhere from here
	e-transition	so we follow an e-transition
Empty	$[F \rightarrow .(E)]$	now we can shift the (
($[F \rightarrow (.(E)]$	building the handle (E); This state says: "I have (on the stack and expect the input to give me tokens that can eventually be reduced to give me the rest of the handle, E)."

4.11 CONSTRUCTING THE SLR PARSING TABLE

To construct the parser table we must convert our NFA into a DFA. The states in the LR table will be the e-closures of the states corresponding to the items SO...the process of creating the LR state table parallels the process of constructing an equivalent DFA from a machine with e-transitions. Been there, done that - this is essentially the subset construction algorithm so we are in familiar territory here.

We need two operations:

closure() and goto().

closure()

If I is a set of items for a grammar G , then $\text{closure}(I)$ is the set of items constructed from I by the two rules: Initially every item in I is added to $\text{closure}(I)$

If $A \rightarrow a.Bb$ is in $\text{closure}(I)$, and $B \rightarrow g$ is a production, then add the initial item $[B \rightarrow .g]$ to I , if it is not already there. Apply this rule until no more new items can be added to $\text{closure}(I)$.

From our grammar above, if I is the set of one item $\{[E' \rightarrow .E]\}$, then $\text{closure}(I)$ contains:

$I_0: E' \rightarrow .E$

$E \rightarrow .E +$

$T E \rightarrow .T$

$T \rightarrow .T *$

$F T \rightarrow .F$

$F \rightarrow .(E)$

$F \rightarrow .id$

goto()

$\text{goto}(I, X)$, where I is a set of items and X is a grammar symbol, is defined to be the closure of the set of all items $[A \rightarrow aX.b]$ such that $[A \rightarrow a.Xb]$ is in I . The idea here is fairly intuitive: if I is the set of items that are valid for some viable prefix g , then $\text{goto}(I, X)$ is the set of items that are valid for the viable prefix gX .

4.12 SETS-OF-ITEMS-CONSTRUCTION

To construct the canonical collection of sets of LR(0) items for *augmented grammar* G' .

procedure $\text{items}(G')$

begin

JBLET

$C := \{closure(\{[S' \rightarrow .S]\})\};$

repeat

for each set of items in C and each grammar symbol X

such that $goto(I, X)$ is not empty and not in C do

add $goto(I, X)$ to C ;

until no more sets of items can be added to C

end;

4.13 ALGORITHM FOR CONSTRUCTING AN SLR PARSING TABLE

Input: augmented grammar G'

Output: SLR parsing table functions action and goto for G'

Method:

Construct $C = \{I_0, I_1, \dots, I_n\}$ the collection of sets of LR(0) items for G' . State i is constructed from I_i :

if $[A \rightarrow a.ab]$ is in I_i and $goto(I_i, a) = I_j$, then set $action[i, a]$ to "shift j ". Here a must be a terminal.

if $[A \rightarrow a.]$ is in I_i , then set $action[i, a]$ to "reduce $A \rightarrow a$ " for all a in $FOLLOW(A)$. Here A may

not be S' .

if $[S' \rightarrow S.]$ is in I_i , then set $action[i, \$]$ to "accept"

If any conflicting actions are generated by these rules, the grammar is not SLR(1) and the algorithm fails to produce a parser. The goto transitions for state i are constructed for all nonterminals A using the rule: If $goto(I_i, A) = I_j$, then $goto[i, A] = j$.

All entries not defined by rules 2 and 3 are made "error".

The initial state of the parser is the one constructed from the set of items containing $[S' \rightarrow .S]$. Let's work an example to get a feel for what is going on,

An Example

(1) $E \rightarrow E * B$

(2) $E \rightarrow E + B$

(3) $E \rightarrow B$

(4) $B \rightarrow 0$

(5) $B \rightarrow 1$

The Action and Goto Table The two LR(0) parsing tables for this grammar look as follows:

	<i>action</i>					<i>goto</i>	
<i>state</i>	*	+	0	1	\$	E	B
0			s1	s2		3	4
1	r4	r4	r4	r4	r4		
2	r5	r5	r5	r5	r5		
3	s5	s6			acc		
4	r3	r3	r3	r3	r3		
5			s1	s2			7
6			s1	s2			8
7	r1	r1	r1	r1	r1		
8	r2	r2	r2	r2	r2		

UNIT -5**5.1 CANONICAL LR PARSING**

By splitting states when necessary, we can arrange to have each state of an LR parser indicate exactly which input symbols can follow a handle a for which there is a possible reduction to A . As the text points out, sometimes the FOLLOW sets give too much information and doesn't (can't) discriminate between different reductions.

The general form of an LR(k) item becomes $[A \rightarrow a.b, s]$ where $A \rightarrow ab$ is a production and s is a string of terminals. The first part ($A \rightarrow a.b$) is called the core and the second part is the lookahead. In LR(1) $|s|$ is 1, so s is a single terminal.

$A \rightarrow ab$ is the usual righthand side with a marker; any a in s is an incoming token in which we are interested. Completed items used to be reduced for every incoming token in $\text{FOLLOW}(A)$, but now we will reduce only if the next input token is in the lookahead set s . If we get two productions $A \rightarrow a$ and $B \rightarrow a$, we can tell them apart when a is a handle on the stack if the corresponding completed items have different lookahead parts. Furthermore, note that the lookahead has no effect for an item of the form $[A \rightarrow a.b, a]$ if b is not ϵ . Recall that our problem occurs for completed items, so what we have done now is to say that an item of the form $[A \rightarrow a., a]$ calls for a reduction by $A \rightarrow a$ only if the next input symbol is a . More formally, an LR(1) item $[A \rightarrow a.b, a]$ is valid for a viable prefix g if there is a derivation

$S \Rightarrow^* s abw$, where $g = sa$, and either a is the first symbol of w , or w is ϵ and a is $\$$.

5.2 ALGORITHM FOR CONSTRUCTION OF THE SETS OF LR(1) ITEMS

Input: grammar G'

Output: sets of LR(1) items that are the set of items valid for one or more viable prefixes of G'

Method:

closure(I)

begin

repeat

for each item $[A \rightarrow a.Bb, a]$ in I ,

each production $B \rightarrow g$ in G' ,

and each terminal b in $\text{FIRST}(ba)$

JBIET

such that $[B \rightarrow \cdot g, b]$ is not in I do
add $[B \rightarrow \cdot g, b]$ to I ;
until no more items can be added to I ;
end;

5.3 goto(I, X)

begin
let J be the set of items $[A \rightarrow aX \cdot b, a]$ such that
 $[A \rightarrow a \cdot Xb, a]$ is in I
return closure(J);
end;
procedure items(G')
begin
 $C := \{\text{closure}(\{S' \rightarrow \cdot S, \$\})\};$
repeat
for each set of items I in C and each grammar symbol X such
that goto(I, X) is not empty and not in C do
add goto(I, X) to C
until no more sets of items can be added to C ;
end;

An example,

Consider the following grammar,

$S' \rightarrow S$

$S \rightarrow CC$

$C \rightarrow cC$

$C \rightarrow d$

Sets of LR(1) items

I0: $S' \rightarrow \cdot S, \$$

$S \rightarrow \cdot CC, \$$

$C \rightarrow \cdot Cc, c/d$

$C \rightarrow \cdot d, c/d$

I1: $S' \rightarrow S \cdot, \$$

I2: $S \rightarrow C \cdot C, \$$

$C \rightarrow \cdot Cc, \$$

$C \rightarrow \cdot d, \$$

JBIET

I3: C → c.C, c/d
C → .Cc, c/d
C → .d, c/d

I4: C → d., c/d

I5: S → CC., \$

I6: C → c.C, \$
C → .cC, \$
C → .d, \$

I7: C → d., \$

I8: C → cC., c/d

I9: C → cC., \$

Here is what the corresponding DFA looks like

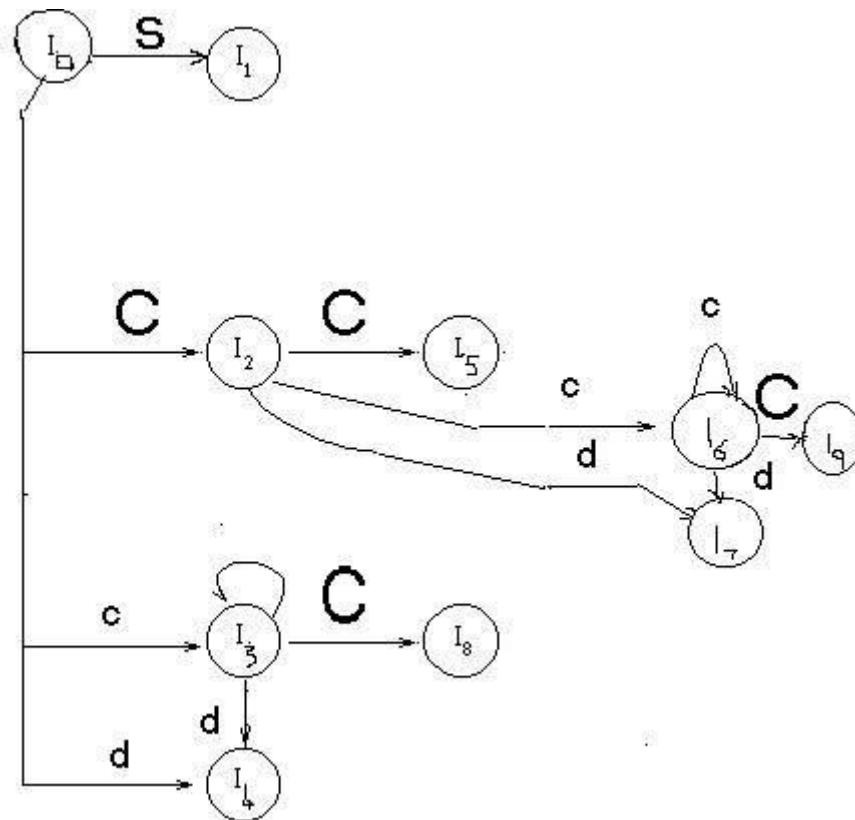

Parsing Table:state	c	d	\$	S	C
0	S3	S4		1	2
1			acc		
2	S6	S7			5
3	S3	S4			8
4	R3	R3			
5			R1		
6	S6	S7			9
7			R3		
8	R2	R2			
9			R2		

5.4 ALGORITHM FOR CONSTRUCTION OF THE CANONICAL LR PARSING TABLE

Input: grammar G'

Output: canonical LR parsing table functions action and goto

1. Construct $C = \{I_0, I_1, \dots, I_n\}$ the collection of sets of LR(1) items for G'. State i is constructed from I_i .
2. if $[A \rightarrow a.ab, b >]$ is in I_i and $\text{goto}(I_i, a) = I_j$, then set $\text{action}[i, a]$ to "shift j ". Here a must be a terminal.
3. if $[A \rightarrow a., a]$ is in I_i , then set $\text{action}[i, a]$ to "reduce $A \rightarrow a$ " for all a in $\text{FOLLOW}(A)$. Here A may *not* be S' .
4. if $[S' \rightarrow S.]$ is in I_i , then set $\text{action}[i, \$]$ to "accept"
5. If any conflicting actions are generated by these rules, the grammar is not LR(1) and the algorithm fails to produce a parser.
6. The goto transitions for state i are constructed for all *nonterminals* A using the rule: If $\text{goto}(I_i, A) = I_j$, then $\text{goto}[i, A] = j$.
7. All entries not defined by rules 2 and 3 are made "error".
8. The initial state of the parser is the one constructed from the set of items containing $[S' \rightarrow .S, \$]$.

5.5.LALR PARSER:

We begin with two observations. First, some of the states generated for LR(1) parsing have the same set of core (or first) components and differ only in their second component, the lookahead symbol. Our intuition is that we should be able to merge these states and reduce the number of states we have, getting close to the number of states that would be generated for LR(0) parsing. This observation suggests a hybrid approach: We can construct the canonical LR(1) sets of items and then look for sets of items having the same core. We merge these sets with common cores into one set of items. The merging of states with common cores can never produce a shift/reduce conflict that was not present in one of the original states because shift actions depend only on the core, not the lookahead. But it is possible for the merger to produce a reduce/reduce conflict.

Our second observation is that we are really only interested in the lookahead symbol in places where there is a problem. So our next thought is to take the LR(0) set of items and add lookaheads only where they are needed. This leads to a more efficient, but much more complicated method.

5.6 ALGORITHM FOR EASY CONSTRUCTION OF AN LALR TABLE

Input: G'

Output: LALR parsing table functions with action and goto for G' .

Method:

1. Construct $C = \{I_0, I_1, \dots, I_n\}$ the collection of sets of LR(1) items for G' .
2. For each core present among the set of LR(1) items, find all sets having that core and replace these sets by the union.
3. Let $C' = \{J_0, J_1, \dots, J_m\}$ be the resulting sets of LR(1) items. The parsing actions for state i are constructed from J_i in the same manner as in the construction of the canonical LR parsing table.
4. If there is a conflict, the grammar is not LALR(1) and the algorithm fails.
5. The goto table is constructed as follows: If J is the union of one or more sets of LR(1) items, that is, $J = I_0 \cup I_1 \cup \dots \cup I_k$, then the cores of $\text{goto}(I_0, X)$, $\text{goto}(I_1, X)$, ..., $\text{goto}(I_k, X)$ are the same, since I_0, I_1, \dots, I_k all have the same core. Let K be the union of all sets of items having the same core as $\text{goto}(I_1, X)$.

JBLET

6. Then $\text{goto}(J, X) = K$.

Consider the above example,

I3 & I6 can be replaced by their union

I36:C->c.C,c/d/\$

C->.Cc,C/D/\$

C->.d,c/d/\$

I47:C->d.,c/d/\$

I89:C->Cc.,c/d/\$

Parsing Table

state	c	d	\$	S	C
0	S36	S47		1	2
1			Accept		
2	S36	S47			5
36	S36	S47			89
47	R3	R3			
5			R1		
89	R2	R2	R2		

5.7 HANDLING ERRORS

The LALR parser may continue to do reductions after the LR parser would have spotted an error, but the LALR parser will never do a shift after the point the LR parser would have discovered the error and will eventually find the error.

5.8 DANGLING ELSE

The dangling else is a problem in [computer programming](#) in which an optional else clause in an [If-then\(-else\)](#) statement results in nested conditionals being ambiguous. Formally, the [context-free grammar](#) of the language is [ambiguous](#), meaning there is more than one correct parse tree.

In many programming languages one may write conditionally executed code in two forms: the if-then form, and the if-then-else form – the else clause is optional:

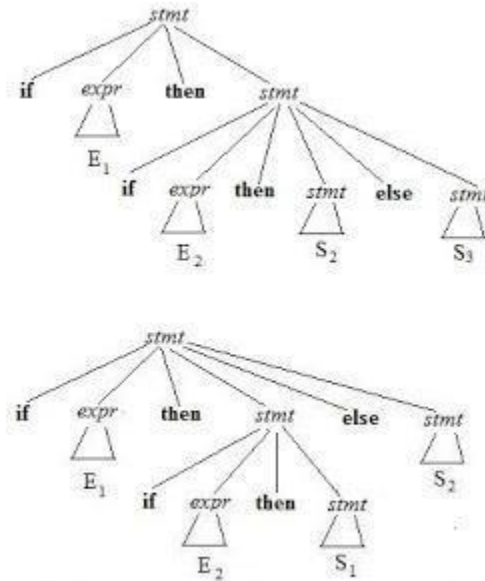

Fig 2.4 Two parse trees for an ambiguous sentence

Consider the grammar:

- S ::= E \$
- E ::= E + E
- | E * E
- | (E)
- | id
- | num

and four of its LALR(1) states:

I0: S ::= . E \$?

- | | | |
|--------------------|------------------------|------------------------|
| E ::= . E + E +*\$ | I1: S ::= E . \$? | I2: E ::= E * . E +*\$ |
| E ::= . E * E +*\$ | E ::= E . + E +*\$ | E ::= . E + E +*\$ |
| E ::= . (E) +*\$ | E ::= E . * E +*\$ | E ::= . E * E +*\$ |
| E ::= . id +*\$ | | E ::= . (E) +*\$ |
| E ::= . num +*\$ | I3: E ::= E * E . +*\$ | E ::= . id +*\$ |
| | E ::= E . + E +*\$ | E ::= . num +*\$ |

$$E ::= E . * E + * \$$$

Here we have a shift-reduce error. Consider the first two items in I3. If we have $a*b+c$ and we parsed $a*b$, do we reduce using $E ::= E * E$ or do we shift more symbols? In the former case we get a parse tree $(a*b)+c$; in the latter case we get $a*(b+c)$. To resolve this conflict, we can specify that $*$ has higher precedence than $+$. The precedence of a grammar production is equal to the precedence of the rightmost token at the rhs of the production. For example, the precedence of the production $E ::= E * E$ is equal to the precedence of the operator $*$, the precedence of the production $E ::= (E)$ is equal to the precedence of the token $)$, and the precedence of the production $E ::= \text{if } E \text{ then } E \text{ else } E$ is equal to the precedence of the token else . The idea is that if the look ahead has higher precedence than the production currently used, we shift. For example, if we are parsing $E + E$ using the production rule $E ::= E + E$ and the look ahead is $*$, we shift $*$. If the look ahead has the same precedence as that of the current production and is left associative, we reduce, otherwise we shift. The above grammar is valid if we define the precedence and associativity of all the operators. Thus, it is very important when you write a parser using CUP or any other LALR(1) parser generator to specify associativities and precedence's for most tokens (especially for those used as operators). Note: you can explicitly define the precedence of a rule in CUP using the `%prec` directive:

$$E ::= \text{MINUS } E \text{ \%prec UMINUS}$$

where UMINUS is a pseudo-token that has higher precedence than TIMES, MINUS etc, so that $-1*2$ is equal to $(-1)*2$, not to $-(1*2)$.

Another thing we can do when specifying an LALR(1) grammar for a parser generator is error recovery. All the entries in the ACTION and GOTO tables that have no content correspond to syntax errors. The simplest thing to do in case of error is to report it and stop the parsing. But we would like to continue parsing finding more errors. This is called *error recovery*. Consider the grammar:

$$S ::= L = E ;$$

$$| \{ SL \}$$

$$; | \text{error} ;$$

$$SL ::= S ; |$$

$$SL S ;$$

The special token error indicates to the parser what to do in case of invalid syntax for S (an invalid statement). In this case, it reads all the tokens from the input stream until it finds the first semicolon. The way the parser handles this is to first push an error state in the stack. In case of an error, the parser pops out elements from the stack until it finds an error state where it can proceed. Then it discards tokens from the input until a restart is possible. Inserting error handling productions in the proper places in a grammar to do good error recovery is considered very hard.

5.9 LR ERROR RECOVERY

An LR parser will detect an error when it consults the parsing action table and find a blank or error entry. Errors are never detected by consulting the goto table. An LR parser will detect an error as soon as there is no valid continuation for the portion of the input thus far scanned. A canonical LR parser will not make even a single reduction before announcing the error. SLR and LALR parsers may make several reductions before detecting an error, but they will never shift an erroneous input symbol onto the stack.

5.10 PANIC-MODE ERROR RECOVERY

We can implement panic-mode error recovery by scanning down the stack until a state s with a goto on a particular nonterminal A is found. Zero or more input symbols are then discarded until a symbol a is found that can legitimately follow A . The parser then stacks the state $GOTO(s, A)$ and resumes normal parsing. The situation might exist where there is more than one choice for the nonterminal A . Normally these would be nonterminals representing major program pieces, e.g. an expression, a statement, or a block. For example, if A is the nonterminal `stmt`, a might be semicolon or `}`, which marks the end of a statement sequence. This method of error recovery attempts to eliminate the phrase containing the syntactic error. The parser determines that a string derivable from A contains an error. Part of that string has already been processed, and the result of this processing is a sequence of states on top of the stack. The remainder of the string is still in the input, and the parser attempts to skip over the remainder of this string by looking for a symbol on the input that can legitimately follow A . By removing states from the stack, skipping over the input, and pushing $GOTO(s, A)$ on the stack, the parser pretends that it has found an instance of A and resumes normal parsing.

5.11 PHRASE-LEVEL RECOVERY

Phrase-level recovery is implemented by examining each error entry in the LR action table and deciding on the basis of language usage the most likely programmer error that would give rise to that error. An appropriate recovery procedure can then be constructed; presumably the top of the stack and/or first input symbol would be modified in a way deemed appropriate for each error entry. In designing specific error-handling routines for an LR parser, we can fill in each blank entry in the action field with a pointer to an error routine that will take the appropriate action selected by the compiler designer.

The actions may include insertion or deletion of symbols from the stack or the input or both, or alteration and transposition of input symbols. We must make our choices so that the LR parser will not get into an infinite loop. A safe strategy will assure that at least one input symbol will be removed or shifted eventually, or that the stack will eventually shrink if the end of the input has been reached. Popping a stack state that covers a non terminal should be avoided, because this modification eliminates from the stack a construct that has already been successfully parsed.

UNIT 6

SEMANTIC ANALYSIS

6.1 SEMANTIC ANALYSIS

- Semantic Analysis computes additional information related to the meaning of the program once the syntactic structure is known.
- In typed languages as C, semantic analysis involves adding information to the symbol table and performing type checking.
- The information to be computed is beyond the capabilities of standard parsing techniques, therefore it is not regarded as syntax.
- As for Lexical and Syntax analysis, also for Semantic Analysis we need both a Representation Formalism and an Implementation Mechanism.
- As representation formalism this lecture illustrates what are called Syntax Directed Translations.

6.2 SYNTAX DIRECTED TRANSLATION

- The Principle of Syntax Directed Translation states that the meaning of an input sentence is related to its syntactic structure, i.e., to its Parse-Tree.
- By Syntax Directed Translations we indicate those formalisms for specifying translations for programming language constructs guided by context-free grammars.
 - We associate Attributes to the grammar symbols representing the language constructs.
 - Values for attributes are computed by Semantic Rules associated with grammar productions.
- Evaluation of Semantic Rules may:
 - Generate Code;
 - Insert information into the Symbol Table;
 - Perform Semantic Check;
 - Issue error messages;
 - etc.

There are two notations for attaching semantic rules:

1. **Syntax Directed Definitions.** High-level specification hiding many implementation details (also called **Attribute Grammars**).
2. **Translation Schemes.** More implementation oriented: Indicate the order in which semantic rules are to be evaluated.

Syntax Directed Definitions

• **Syntax Directed Definitions** are a generalization of context-free grammars in which:

1. Grammar symbols have an associated set of **Attributes**;
2. Productions are associated with **Semantic Rules** for computing the values of attributes.
 - Such formalism generates **Annotated Parse-Trees** where each node of the tree is a record with a field for each attribute (e.g., $X.a$ indicates the attribute a of the grammar symbol X).
 - The value of an attribute of a grammar symbol at a given parse-tree node is defined by a semantic rule associated with the production used at that node.

We distinguish between two kinds of attributes:

1. **Synthesized Attributes.** They are computed from the values of the attributes of the children nodes.
2. **Inherited Attributes.** They are computed from the values of the attributes of both the siblings and the parent nodes

Syntax Directed Definitions: An Example

• **Example.** Let us consider the Grammar for arithmetic expressions. The Syntax Directed Definition associates to each non terminal a synthesized attribute called *val*.

PRODUCTION	SEMANTIC RULE
$L \rightarrow En$	$print(E.val)$
$E \rightarrow E_1 + T$	$E.val := E_1.val + T.val$
$E \rightarrow T$	$E.val := T.val$
$T \rightarrow T_1 * F$	$T.val := T_1.val * F.val$
$T \rightarrow F$	$T.val := F.val$
$F \rightarrow (E)$	$F.val := E.val$
$F \rightarrow digit$	$F.val := digit.lexval$

6.3 S-ATTRIBUTED DEFINITIONS

Definition. An **S-Attributed Definition** is a Syntax Directed Definition that uses only synthesized attributes.

- **Evaluation Order.** Semantic rules in a S-Attributed Definition can be evaluated by a bottom-up, or PostOrder, traversal of the parse-tree.
- **Example.** The above arithmetic grammar is an example of an S-Attributed Definition. The annotated parse-tree for the input 3*5+4n is:

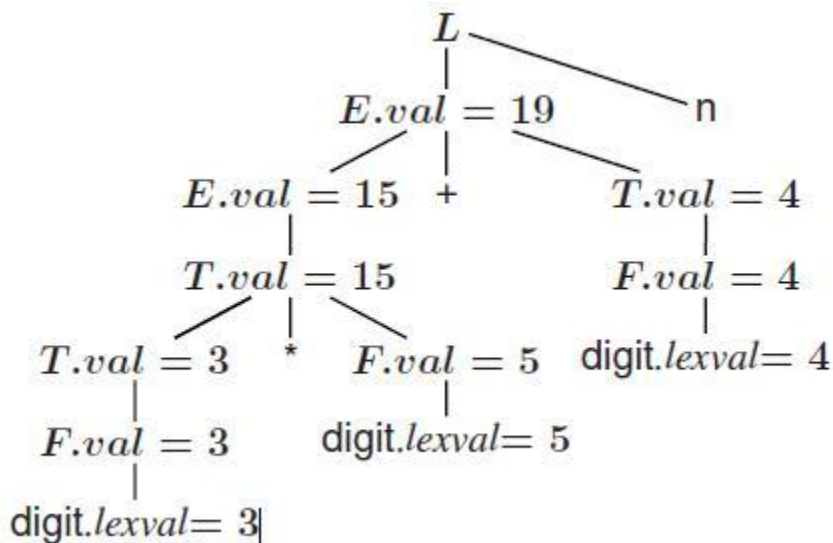

6.4 L-attributed definition

Definition: A SDD is *L-attributed* if each inherited attribute of X_i in the RHS of $A \rightarrow X_1 : X_2 \dots X_n$ depends only on

1. attributes of $X_1; X_2; \dots; X_{i-1}$ (symbols to the left of X_i in the RHS)
2. inherited attributes of A .

Restrictions for translation schemes:

1. Inherited attribute of X_i must be computed by an action before X_i .
2. An action must not refer to synthesized attribute of any symbol to the right of that action.
3. Synthesized attribute for A can only be computed after all attributes it references have been completed (usually at end of RHS).

6.5 SYMBOL TABLES

A symbol table is a major data structure used in a compiler. Associates attributes with identifiers used in a program. For instance, a type attribute is usually associated with each identifier. A symbol table is a necessary component. Definition (declaration) of identifiers appears once in a program. Use of identifiers may appear in many places of the program text. Identifiers and attributes are entered by the analysis phases. When processing a definition (declaration) of an identifier. In simple languages with only global variables and implicit declarations. The scanner can enter an identifier into a symbol table if it is not already there. In block-structured languages with scopes and explicit declarations:

The parser and/or semantic analyzer enter identifiers and corresponding attributes

Symbol table information is used by the analysis and synthesis phases

To verify that used identifiers have been defined (declared)

To verify that expressions and assignments are semantically correct – type checking

To generate intermediate or target code



Symbol Table Interface

The basic operations defined on a symbol table include:

- allocate – to allocate a new empty symbol table
- free – to remove all entries and free the storage of a symbol table
- insert – to insert a name in a symbol table and return a pointer to its entry

JBLET

- lookup – to search for a name and return a pointer to its entry
- set_attribute – to associate an attribute with a given entry
- get_attribute – to get an attribute associated with a given entry

Other operations can be added depending on requirement For example, a delete operation removes a name previously inserted Some identifiers become invisible (out of scope) after exiting a block

This interface provides an abstract view of a symbol table

Supports the simultaneous existence of multiple tables

Implementation can vary without modifying the interface

Basic Implementation Techniques

First consideration is how to insert and lookup names

Variety of implementation techniques

Unordered List

Simplest to implement

Implemented as an array or a linked list

Linked list can grow dynamically – alleviates problem of a fixed size array

Insertion is fast $O(1)$, but lookup is slow for large tables – $O(n)$ on average

Ordered List

If an array is sorted, it can be searched using binary search – $O(\log_2 n)$

Insertion into a sorted array is expensive – $O(n)$ on average

Useful when set of names is known in advance – table of reserved words

Binary Search Tree

Can grow dynamically

Insertion and lookup are $O(\log_2 n)$ on average

6.6 HASH TABLES AND HASH FUNCTIONS

- ✓ A hash table is an array with index range: 0 to $TableSize - 1$
- ✓ Most commonly used data structure to implement symbol tables
- ✓ Insertion and lookup can be made very fast – $O(1)$
- ✓ A hash function maps an identifier name into a table index

JBIET

- ✓ A hash function, $h(name)$, should depend solely on $name$
- ✓ $h(name)$ should be computed quickly
- ✓ h should be uniform and randomizing in distributing names
- ✓ All table indices should be mapped with equal probability.
- ✓ Similar names should not cluster to the same table index

6.7 HASH FUNCTIONS

_ Hash functions can be defined in many ways . . .

_ A string can be treated as a sequence of integer words
_ Several characters are fit into an integer word

_ Strings longer than one word are folded using exclusive-or or addition
_ Hash value is obtained by taking integer word modulo $TableSize$

_ We can also compute a hash value character by character:

_ $h(name) = (c_0 + c_1 + \dots + c_{n-1}) \bmod TableSize$, where n is $name$ length
_ $h(name) = (c_0 * c_1 * \dots * c_{n-1}) \bmod TableSize$

_ $h(name) = (c_{n-1} + \dots + c_1 + c_0) \bmod TableSize$
_ $h(name) = (c_0 * c_{n-1} * n) \bmod TableSize$

6.8 RUNTIME ENVIRONMENT

- Runtime organization of different storage locations
- Representation of scopes and extents during program execution.
- Components of executing program reside in blocks of memory (supplied by OS).
- Three kinds of entities that need to be managed at runtime:
 - Generated code for various procedures and programs.

forms text or code segment of your program: size known at compile time.
○ Data objects:

Global variables/constants: size known at compile time

Variables declared within procedures/blocks: size known

Variables created dynamically: size unknown.

- Stack to keep track of procedure activations.

Subdivide memory conceptually into code and data areas:

- Code: Program instructions
- Stack: Manage activation of procedures at runtime.
- Heap: holds variables created dynamically

6.9 STORAGE ORGANIZATION

1 Fixed-size objects can be placed in predefined locations.

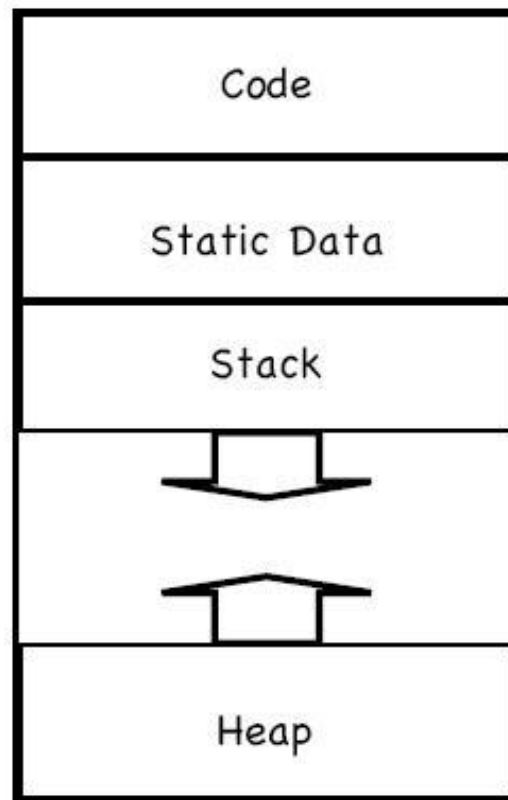

2. Run-time stack and heap The

STACK is used to store:

- Procedure activations.
- The status of the machine just before calling a procedure, so that the status can be restored when the called procedure returns.
- The HEAP stores data allocated under program control (e.g. by malloc() in C).

Activation records

Any information needed for a single activation of a procedure is stored in the ACTIVATION RECORD (sometimes called the STACK FRAME). Today, we'll assume the stack grows DOWNWARD, as on, e.g., the Intel architecture. The activation record gets pushed for each procedure call and popped for each procedure return.

6.9 STATIC ALLOCATION

Statically allocated names are bound to storage at compile time. Storage bindings of statically allocated names never change, so even if a name is local to a procedure, its name is always bound to the same storage. The compiler uses the type of a name (retrieved from the symbol table) to determine storage size required. The required number of bytes (possibly aligned) is set aside for the name. The address of the storage is fixed at compile time.

Limitations:

- The size required must be known at compile time.
- Recursive procedures cannot be implemented as all locals are statically allocated.
- No data structure can be created dynamically as all data is static.



Stack-dynamic allocation

- ✓ Storage is organized as a stack.
- ✓ Activation records are pushed and popped.
- ✓ Locals and parameters are contained in the activation records for the call.
- ✓ This means locals are bound to fresh storage on every call.
- ✓ If we have a stack growing downwards, we just need a stack_top pointer.
- ✓ To allocate a new activation record, we just increase stack_top.
- ✓ To deallocate an existing activation record, we just decrease stack_top.



Address generation in stack allocation

The position of the activation record on the stack cannot be determined statically. Therefore the compiler must generate addresses RELATIVE to the activation record. If we have a downward-growing stack and a stack_top pointer, we generate addresses of the form stack_top + offset

6.10 HEAP ALLOCATION

Some languages do not have tree-structured allocations. In these cases, activations have to be allocated on the heap. This allows strange situations, like callee activations that live longer than their callers' activations. This is not common Heap is used for allocating space for objects created at run time For example: nodes of dynamic data structures such as linked lists and trees

Dynamic memory allocation and deallocation based on the requirements of the program *malloc()* and *free()* in C programs

new() and *delete()* in C++ programs

new() and garbage collection in Java programs

Allocation and deallocation may be *completely manual* (C/C++), *semi-automatic* (Java), or *fully automatic* (Lisp)

6.11 PARAMETERS PASSING

A language has first-class functions if functions can be declared within any scope passed as arguments to other functions returned as results of functions. In a language with first-class functions and static scope, a function value is generally represented by a closure. a pair consisting of a pointer to function code a pointer to an activation record. Passing functions as arguments is very useful in structuring of systems using upcalls

An example:

```
main()
{ int x = 4;
  int f (int y) {
  return x*y;
  }
  int g (int →int h){
  int x = 7;
  return h(3) + x;
  }
```

```
g(f); // returns 12
}
```

Passing Functions as Parameters – Implementation with Static Scope

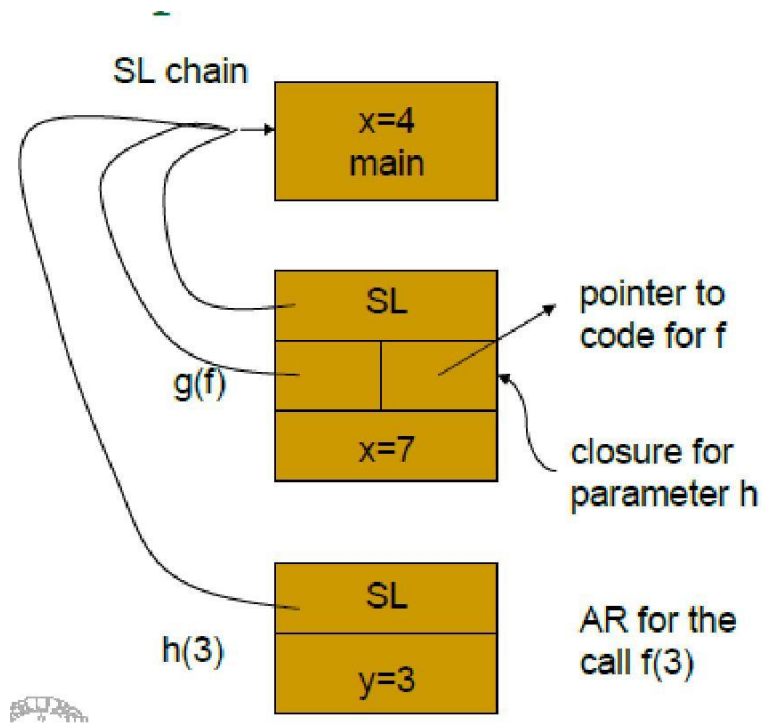

An example:

```
main()
{ int x = 4;
  int f (int y) {
    return x*y;
  }
  int g (int → int h){
    int x = 7;
    return h(3) + x;
  }
  g(f); // returns 12
}
```

UNIT 7

INTERMEDIATE CODE

7.1. INTERMEDIATE CODE GENERATION

In the analysis-synthesis model of a compiler, the front end analyzes a source program and creates an intermediate representation, from which the back end generates target code. This facilitates *retargeting*: enables attaching a back end for the new machine to an existing front end.

Logical Structure of a Compiler Front End



A compiler front end is organized as in figure above, where parsing, static checking, and intermediate-code generation are done sequentially; sometimes they can be combined and folded into parsing. All schemes can be implemented by creating a syntax tree and then walking the tree.

Static Checking

This includes type checking which ensures that operators are applied to compatible operands. It also includes any syntactic checks that remain after parsing like

flow-of-control checks

- Ex: Break statement within a loop construct

Uniqueness checks

- Labels in case statements

Name-related checks

Intermediate Representations

We could translate the source program directly into the target language. However, there are benefits to having an intermediate, machine-independent representation.

JBLET

- A clear distinction between the machine-independent and machine-dependent parts of the compiler
- Retargeting is facilitated the implementation of language processors for new machines will require replacing only the back-end.
- We could apply machine independent code optimization techniques

Intermediate representations span the gap between the source and target languages.

• *High Level Representations*

- closer to the source language
- easy to generate from an input program
- code optimizations may not be straightforward

• *Low Level Representations*

- closer to the target machine
- Suitable for register allocation and instruction selection
- easier for optimizations, final code generation

There are several options for intermediate code. They can be either

- Specific to the language being implemented

P-code for Pascal

Byte code for Java

7.2 LANGUAGE INDEPENDENT 3-ADDRESS CODE

IR can be either an actual language or a group of internal data structures that are shared by the phases of the compiler. C used as intermediate language as it is flexible, compiles into efficient machine code and its compilers are widely available. In all cases, the intermediate code is a linearization of the syntax tree produced during syntax and semantic analysis. It is formed by breaking down the tree structure into sequential instructions, each of which is equivalent to a single, or small number of machine instructions. Machine code can then be generated (access might be required to symbol tables etc). TAC can range from high- to low-level, depending on the choice of operators. In general, it is a statement containing at most 3 addresses or operands.

The general form is $x := y \text{ op } z$, where “op” is an operator, x is the result, and y and z are operands. **x, y, z** are variables, constants, or “temporaries”. A three-address instruction

JBLET

consists of at most 3 addresses for each statement.

It is a linearized representation of a binary syntax tree. Explicit names correspond to interior nodes of the graph. E.g. for a looping statement, syntax tree represents components of the statement, whereas three-address code contains labels and jump instructions to represent the flow-of-control as in machine language. A TAC instruction has at most one operator on the RHS of an instruction; no built-up arithmetic expressions are permitted.

e.g. $x + y * z$ can be translated

as $t1 = y * z$

$t2 = x + t1$

Where $t1$ & $t2$ are compiler-generated temporary names.

5Since it unravels multi-operator arithmetic expressions and nested control-flow statements, it is useful for target code generation and optimization.

Addresses and Instructions

- TAC consists of a sequence of instructions, each instruction may have up to three addresses, prototypically $t1 = t2 \text{ op } t3$
- Addresses may be one of:
 - A name. Each name is a symbol table index. For convenience, we write the names as the identifier.
 - A constant.
 - A compiler-generated temporary. Each time a temporary address is needed, the compiler generates another name from the stream $t1, t2, t3$, etc.
- Temporary names allow for code optimization to easily move instructions
- At target-code generation time, these names will be allocated to registers or to memory.
- TAC Instructions
 - Symbolic labels will be used by instructions that alter the flow of control.

The instruction addresses of labels will be filled in later.

L: $t1 = t2 \text{ op } t3$

- Assignment instructions: $x = y \text{ op } z$
- Includes binary arithmetic and logical operations
 - Unary assignments: $x = \text{op } y$

JBLET

- Includes unary arithmetic op (-) and logical op (!) and type conversion

- Copy instructions: $x = y$
- Unconditional jump: goto L

- L is a symbolic label of an instruction

- Conditional jumps:

if x goto L If x is true, execute instruction L next

ifFalse x goto L If x is false, execute instruction L next

- Conditional jumps:

if x relop y goto L

– Procedure calls. For a procedure call $p(x_1, \dots, x_n)$

param x_1

...

param x_n

call p, n

– Function calls : $y = p(x_1, \dots, x_n)$ $y = \text{call } p, n$, return y

– Indexed copy instructions: $x = y[i]$ and $x[i] = y$



Left: sets x to the value in the location i memory units beyond y



Right: sets the contents of the location i memory units beyond x to y

– Address and pointer instructions:

- $x = \&y$ sets the value of x to be the location (address) of y.

- $x = *y$, presumably y is a pointer or temporary whose value is a location. The value of x is set to the contents of that location.

- $*x = y$ sets the value of the object pointed to by x to the value of y.

Example: Given the statement **do i = i+1; while (a[i] < v);** , the TAC can be written as below in two ways, using either symbolic labels or position number of instructions for labels.

Types of three address code

There are different types of statements in source program to which three address code has to be generated. Along with operands and operators, three address code also use labels to provide flow of control for statements like if-then-else, for and while. The different types of three address code statements are:

Assignment statement

$a = b \text{ op } c$

In the above case b and c are operands, while op is binary or logical operator. The result of applying op on b and c is stored in a.

Unary operation

$a = \text{op } b$ This is used for unary minus or logical negation. Example: $a = b * (-c) + d$

Three address code for the above example will be

$t1 = -c$

$t2 = t1 * b$

$t3 = t2 +$

d
 $a = t3$

Copy Statement

$a = b$

The value of b is stored in variable a.

Unconditional jump

goto L

Creates label L and generates three-address code 'goto L'

v. Creates label L, generate code for expression exp, If the exp returns value true then go to the statement labelled L. exp returns a value false go to the statement immediately following the if statement.

Function call

For a function fun with n arguments $a_1, a_2, a_3, \dots, a_n$
ie., $\text{fun}(a_1, a_2, a_3, \dots, a_n)$,

JBLET

the three address code will
be Param a1

Param a2

...

Param an

Call fun, n

Where param defines the arguments to function.

Array indexing

In order to access the elements of array either single dimension or multidimension, three address code requires base address and offset value. Base address consists of the address of first element in an array. Other elements of the array can be accessed using the base address and offset value.

Example: $x = y[i]$

Memory location $m = \text{Base address of } y + \text{Displacement}$

i $x = \text{contents of memory location } m$

similarly $x[i] = y$

Memory location $m = \text{Base address of } x + \text{Displacement}$

i The value of y is stored in memory location m

Pointer assignment

$x = \&y$ x stores the address of memory location y

$x = *y$ y is a pointer whose r-value is location

$*x = y$ sets r-value of the object pointed by x to the r-value of y

Intermediate representation should have an operator set which is rich to implement most of the

operations of source language. It should also help in mapping to restricted instruction set of target machine.

Data Structure

Three address code is represented as record structure with fields for operator and operands.

These

records can be stored as array or linked list. Most common implementations of three address code are-

Quadruples, Triples and Indirect triples.

7.3 QUADRUPLES-

Quadruples consists of four fields in the record structure. One field to store operator op, two fields to store operands or arguments arg1 and arg2 and one field to store result res. $res = arg1 \text{ op } arg2$

Example: $a = b + c$

b is represented as arg1, c is represented as arg2, + as op and a as res.

Unary operators like '-' do not use arg2. Operators like param do not use arg2 nor result. For conditional and unconditional statements res is label. Arg1, arg2 and res are pointers to symbol table or literal table for the names.

Example: $a = -b * d + c + (-b) * d$

Three address code for the above statement is as follows

$t1 = -b$

$t2 = t1 * d$

$t3 = t2 + c$

$t4 = -b$

$t5 = t4 * d$

$t6 = t3 + t5$

$a = t6$

Quadruples for the above example is as follows

Op	Arg1	Arg2	Res
-	B		t1
*	t1	d	t2
+	t2	c	t3
-	B		t4
*	t4	d	t5
+	t3	t5	t6
=	t6		a

7.4 TRIPLES

Triples uses only three fields in the record structure. One field for operator, two fields for operands named as arg1 and arg2. Value of temporary variable can be accessed by the position of the statement the computes it and not by location as in quadruples.

Example: $a = -b * d + c + (-b) * d$

Triples for the above example is as follows

Stmt no	Op	Arg1	Arg2
(0)	-	b	
(1)	*	d	(0)
(2)	+	c	(1)
(3)	-	b	
(4)	*	d	(3)
(5)	+	(2)	(4)
(6)	=	a	(5)

Arg1 and arg2 may be pointers to symbol table for program variables or literal table for constant or pointers into triple structure for intermediate results.

Example: Triples for statement $x[i] = y$ which generates two records is as follows

Stmt no	Op	Arg1	Arg2
(0)	[]=	x	i
(1)	=	(0)	y

Triples for statement $x = y[i]$ which generates two records is as follows

Stmt no	Op	Arg1	Arg2
(0)	=[]	y	i
(1)	=	x	(0)

Triples are alternative ways for representing syntax tree or Directed acyclic graph for program defined names.

Indirect Triples

Indirect triples are used to achieve indirection in listing of pointers. That is, it uses pointers to triples than listing of triples themselves.

Example: $a = -b * d + c + (-b) * d$

	Stmt no	Stmt no	Op	Arg1	Arg2
(0)	(10)	(10)	-	b	
(1)	(11)	(11)	*	d	(0)
(2)	(12)	(12)	+	c	(1)
(3)	(13)	(13)	-	b	
(4)	(14)	(14)	*	d	(3)
(5)	(15)	(15)	+	(2)	(4)
(6)	(16)	(16)	=	a	(5)

Conditional operator and operands. Representations include quadruples, triples and indirect triples.

7.5 SYNTAX TREES

Syntax trees are high level IR. They depict the natural hierarchical structure of the source program. Nodes represent constructs in source program and the children of a node represent meaningful components of the construct. Syntax trees are suited for static type checking.

Variants of Syntax Trees: DAG

A directed acyclic graph (DAG) for an expression identifies the common sub expressions (sub expressions that occur more than once) of the expression. DAG's can be constructed by using the same techniques that construct syntax trees.

A DAG has leaves corresponding to atomic operands and interior nodes corresponding to operators. A node N in a DAG has more than one parent if N represents a common sub expression, so a DAG represents expressions concisely. It gives clues to compiler about the generating efficient code to evaluate expressions.

Example 1: Given the grammar below, for the input string $id + id * id$, the parse tree,

syntax tree and the DAG are as shown.

Syntax tree:

Grammar :

$E \rightarrow E + T \mid T$
 $T \rightarrow T * F \mid F$
 $F \rightarrow (E) \mid id$

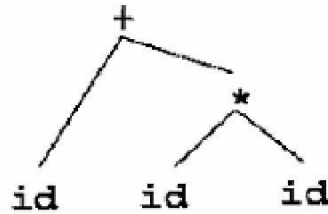

Parse tree:

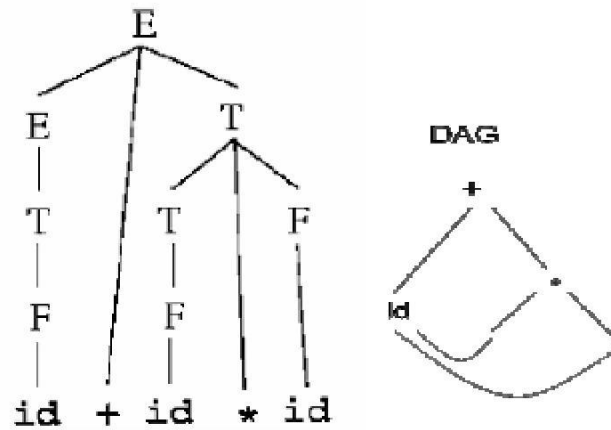

Example : DAG for the expression $a + a * (b - c) + (b - c) * d$ is shown below.

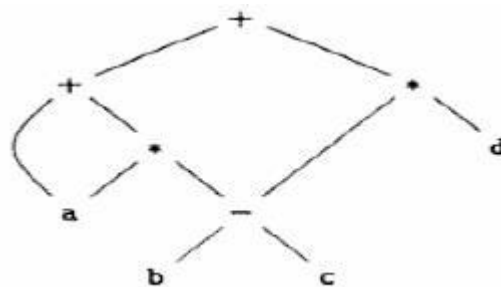

Using the SDD to draw syntax tree or DAG for a given expression:-

- Draw the parse tree
 - Perform a post order traversal of the parse tree
 - Perform the semantic actions at every node during the traversal
- Constructs a DAG if before creating a new node, these functions check whether an identical node already exists. If yes, the existing node is returned.

SDD to produce Syntax trees or DAG is shown below.

PRODUCTION	SEMANTIC RULES
1) $E \rightarrow E_1 + T$	$E.node = \text{new Node}('+', E_1.node, T.node)$
2) $E \rightarrow E_1 - T$	$E.node = \text{new Node}('-', E_1.node, T.node)$
3) $E \rightarrow T$	$E.node = T.node$
4) $T \rightarrow (E)$	$T.node = E.node$
5) $T \rightarrow \text{id}$	$T.node = \text{new Leaf}(\text{id}, \text{id.entry})$
6) $T \rightarrow \text{num}$	$T.node = \text{new Leaf}(\text{num}, \text{num.val})$

For the expression $a + a * (b - c) + (b - c) * d$, steps for constructing the DAG is as below.

- 1) $p_1 = \text{Leaf}(\text{id}, \text{entry-a})$
- 2) $p_2 = \text{Leaf}(\text{id}, \text{entry-a}) = p_1$
- 3) $p_3 = \text{Leaf}(\text{id}, \text{entry-b})$
- 4) $p_4 = \text{Leaf}(\text{id}, \text{entry-c})$
- 5) $p_5 = \text{Node}('-', p_3, p_4)$
- 6) $p_6 = \text{Node}('*', p_1, p_5)$
- 7) $p_7 = \text{Node}('+', p_1, p_6)$
- 8) $p_8 = \text{Leaf}(\text{id}, \text{entry-b}) = p_3$
- 9) $p_9 = \text{Leaf}(\text{id}, \text{entry-c}) = p_4$
- 10) $p_{10} = \text{Node}('-', p_8, p_9) = p_5$
- 11) $p_{11} = \text{Leaf}(\text{id}, \text{entry-d})$
- 12) $p_{12} = \text{Node}('*', p_5, p_{11})$
- 13) $p_{13} = \text{Node}('+', p_7, p_{12})$

7.6 BASIC BLOCKS AND FLOW GRAPHS

A graph representation of three-address statements, called a flow graph, is useful for understanding code-generation algorithms, even if the graph is not explicitly constructed by a code-generation algorithm. Nodes in the flow graph represent computations, and the edges represent the flow of control. Flow graph of a program can be used as a vehicle to collect information about the intermediate program. Some register-assignment algorithms use flow graphs to find the inner loops where a program is expected to spend most of its time.

BASIC BLOCKS

A basic block is a sequence of consecutive statements in which flow of control enters at the beginning and leaves at the end without halt or possibility of branching except at the end. The following sequence of three-address statements forms a basic block:

```
t1 := a*a
t2 := a*b
t3 := 2*t2
t4 := t1+t3
t5 := b*b
t6 := t4+t5
```

A three-address statement $x := y+z$ is said to define x and to use y or z . A name in a basic block is said to live at a given point if its value is used after that point in the program, perhaps in another basic block.

The following algorithm can be used to partition a sequence of three-address statements into basic blocks.

Algorithm 1: Partition into basic blocks.

Input: A sequence of three-address statements.

Output: A list of basic blocks with each three-address statement in exactly one block. Method:

1. We first determine the set of leaders, the first statements of basic blocks. The rules we use are the following:

- I) The first statement is a leader.
- II) Any statement that is the target of a conditional or unconditional goto is a leader.

JBLET

III) Any statement that immediately follows a goto or conditional goto statement is a leader.

2. For each leader, its basic block consists of the leader and all statements up to but not including the next leader or the end of the program.

Example 3: Consider the fragment of source code shown in fig. 7; it computes the dot product of two vectors a and b of length 20. A list of three-address statements performing this computation on our target machine is shown in fig. 8.

```
begin
prod :=
0; i := 1;
do begin
prod := prod + a[i] *
b[i]; i := i+1;
end
while i<=
20 end
```

Let us apply Algorithm 1 to the three-address code in fig 8 to determine its basic blocks. statement (1) is a leader by rule (I) and statement (3) is a leader by rule (II), since the last statement can jump to it. By rule (III) the statement following (12) is a leader. Therefore, statements (1) and (2) form a basic block. The remainder of the program beginning with statement (3) forms a second basic block.

```
(1) prod := 0
(2) i := 1
(3) t1 := 4*i
(4) t2 := a [ t1 ]
(5) t3 := 4*i
(6) t4 :=b [ t3 ]
(7) t5 := t2*t4
(8) t6 := prod +t5
(9) prod := t6
(10) t7 := i+1
```

(11) $i := t7$

(12) if $i \leq 20$ goto (3)

7.7 TRANSFORMATIONS ON BASIC BLOCKS

A basic block computes a set of expressions. These expressions are the values of the names live on exit from block. Two basic blocks are said to be equivalent if they compute the same set of expressions. A number of transformations can be applied to a basic block without changing the set of expressions computed by the block. Many of these transformations are useful for improving the quality of code that will be ultimately generated from a basic block. There are two important classes of local transformations that can be applied to basic blocks; these are the structure-preserving transformations and the algebraic transformations.

7.8 STRUCTURE-PRESERVING TRANSFORMATIONS

The primary structure-preserving transformations on basic blocks are:

1. Common sub-expression elimination
2. Dead-code elimination
3. Renaming of temporary variables
4. Interchange of two independent adjacent statements

We assume basic blocks have no arrays, pointers, or procedure calls. 1. **Common sub-expression elimination**

Consider the basic block

$a := b + c$

$b := a - d$

$c := b + c$

$d := a - d$

The second and fourth statements compute the same expression, namely $b + c - d$, and hence this basic block may be transformed into the equivalent block

$a := b + c$

$b := a - d$

$c := b + c \quad d := b$

Although the 1st and 3rd statements in both cases appear to have the same expression

on the right, the second statement redefines b. Therefore, the value of b in the 3rd statement is different from the value of b in the 1st, and the 1st and 3rd statements do not compute the same expression.

2. Dead-code elimination

Suppose x is dead, that is, never subsequently used, at the point where the statement $x := y + z$ appears in a basic block. Then this statement may be safely removed without changing the value of the basic block.

3. Renaming temporary variables

Suppose we have a statement $t := b + c$, where t is a temporary. If we change this statement to $u := b + c$, where u is a new temporary variable, and change all uses of this instance of t to u, then the value of the basic block is not changed.

4. Interchange of statements

Suppose we have a block with the two adjacent statements

$$t1 := b + c$$

$$t2 := x + y$$

Then we can interchange the two statements without affecting the value of the block if and only if neither x nor y is t1 and neither b nor c is t2. A normal-form basic block permits all statement interchanges that are possible.

7.9 DAG REPRESENTATION OF BASIC BLOCKS

The goal is to obtain a visual picture of how information flows through the block. The leaves will show the values entering the block and as we proceed up the DAG we encounter uses of these values defs (and redefs) of values and uses of the new values.

Formally, this is defined as follows.

1. Create a leaf for the initial value of each variable appearing in the block. (We do not know what that the value is, not even if the variable has ever been given a value).
2. Create a node N for each statement s in the block.
 - i. Label N with the operator of s. This label is drawn inside the node.
 - ii. Attach to N those variables for which N is the last def in the block. These additional labels are drawn along side of N.
 - iii. Draw edges from N to each statement that is the last def of an operand used by N.

2. Designate as output nodes those N whose values are live on exit, an officially-mysterious term meaning values possibly used in another block. (Determining the live on exit values requires global, i.e., inter-block, flow analysis.) As we shall see in the next few sections various basic-block optimizations are facilitated by using the DAG.

Finding Local Common Subexpressions

As we create nodes for each statement, proceeding in the static order of the statements, we might notice that a new node is just like one already in the DAG in which case we don't need a new node and can use the old node to compute the new value in addition to the one it already was computing. Specifically, we do not construct a new node if an existing node has the same children in the same order and is labeled with the same operation.

Consider computing the DAG for the following block of

code. $a = b + c$

$c = a + x$

$d = b + c$

$b = a + x$

The DAG construction is explained as follows (the movie on the right accompanies the explanation).

1. First we construct leaves with the initial values.
2. Next we process $a = b + c$. This produces a node labeled $+$ with a attached and having b_0 and c_0 as children.
3. Next we process $c = a + x$.
4. Next we process $d = b + c$. Although we have already computed $b + c$ in the first statement, the c 's are not the same, so we produce a new node.
5. Then we process $b = a + x$. Since we have already computed $a + x$ in statement 2, we do not produce a new node, but instead attach b to the old node.
6. Finally, we tidy up and erase the unused initial values.

You might think that with only three computation nodes in the DAG, the block could be reduced to three statements (dropping the computation of b). However, this is wrong. Only if b is dead on exit can we omit the computation of b . We can, however, replace the last statement with the simpler $b = c$. Sometimes a combination of techniques finds

improvements that no single technique would find. For example if $a-b$ is computed, then both a and b are incremented by one, and then $a-b$ is computed again, it will not be recognized as a common subexpression even though the value has not changed. However, when combined with various algebraic transformations, the common value can be recognized.

7.10 DEAD CODE ELIMINATION

Assume we are told (by global flow analysis) that certain values are dead on exit. We examine each root (node with no ancestor) and delete any that have no live variables attached. This process is repeated since new roots may have appeared.

For example, if we are told, for the picture on the right, that only a and b are live, then the root d can be removed since d is dead. Then the rightmost node becomes a root, which also can be removed (since c is dead).

The Use of Algebraic Identities

Some of these are quite clear. We can of course replace $x+0$ or $0+x$ by simply x . Similar Considerations apply to $1*x$, $x*1$, $x-0$, and $x/1$.

Strength reduction

Another class of simplifications is strength reduction, where we replace one operation by a cheaper one. A simple example is replacing $2*x$ by $x+x$ on architectures where addition is cheaper than multiplication. A more sophisticated strength reduction is applied by compilers that recognize induction variables (loop indices). Inside a for i from 1 to N loop, the expression $4*i$ can be strength reduced to $j=j+4$ and 2^i can be strength reduced to $j=2*j$ (with suitable initializations of j just before the loop). Other uses of algebraic identities are possible; many require a careful reading of the language

reference manual to ensure their legality. For example, even though it might be advantageous to convert $((a + b) * f(x)) * a$ to $((a + b) * a) * f(x)$

it is illegal in Fortran since the programmer's use of parentheses to specify the order of operations can not be violated.

Does

$$a = b + c$$

$$x = y + c + b + r$$

JBIET

contain a common sub expression of $b+c$ that need be evaluated only once?

The answer depends on whether the language permits the use of the associative and commutative law for addition. (Note that the associative law is invalid for floating point numbers.)

UNIT-8

OPTIMIZATION

8.1 PRINCIPLE SOURCES OF OPTIMIZATION

A transformation of a program is called local if it can be performed by looking only at the statements in a basic block; otherwise, it is called global. Many transformations can be performed at both the local and global levels. Local transformations are usually performed first.

Function-Preserving Transformations There are a number of ways in which a compiler can improve a program without changing the function it computes. Common sub expression elimination, copy propagation, deadcode elimination, and constant folding are common examples of such function-preserving transformations. The other transformations come up primarily when global optimizations are performed. Frequently, a program will include several calculations of the same value, such as an offset in an array. Some of these duplicate calculations cannot be avoided by the programmer because they lie below the level of detail accessible within the source language. For example, block B5 recalculates $4*i$ and $4*j$.

Common Sub expressions An occurrence of an expression E is called a common sub expression if E was previously computed, and the values of variables in E have not changed since the previous computation. We can avoid re computing the expression if we can use the previously computed value. For example, the assignments to t7 and t10 have the common sub expressions $4*I$ and $4*j$, respectively, on the right side in Fig. They have been eliminated in Fig by using t6 instead of t7 and t8 instead of t10. This change is what would result if we reconstructed the intermediate code from the dag for the basic block.

Example: the above Fig shows the result of eliminating both global and local common sub expressions from blocks B5 and B6 in the flow graph of Fig. We first discuss the transformation of B5 and then mention some subtleties involving arrays.

After local common sub expressions are eliminated B5 still evaluates $4*i$ and $4*j$, as

JBLET

Shown in the earlier fig. Both are common sub expressions; in particular, the three statements $t8 := 4*j$; $t9 := a[t[8]]$; $a[t8] := x$ in B5 can be replaced by $t9 := a[t4]$; $a[t4] := x$ using $t4$ computed in block B3. In Fig. observe that as control passes from the evaluation of $4*j$ in B3 to B5, there is no change in j , so $t4$ can be used if $4*j$ is needed.

Another common sub expression comes to light in B5 after $t4$ replaces $t8$. The new expression $a[t4]$ corresponds to the value of $a[j]$ at the source level. Not only does j retain its value as control leaves $b3$ and then enters B5, but $a[j]$, a value computed into a temporary $t5$, does too because there are no assignments to elements of the array a in the interim. The statement $t9 := a[t4]$; $a[t6] := t9$ in B5 can therefore be replaced by

$a[t6] := t5$ The expression in blocks B1 and B6 is not considered a common sub expression although $t1$ can be used in both places. After control leaves B1 and before it reaches B6, it can go through B5, where there are assignments to a . Hence, $a[t1]$ may not have the same value on reaching B6 as it did in leaving B1, and it is not safe to treat $a[t1]$ as a common sub expression.

Copy Propagation

Block B5 in Fig. can be further improved by eliminating x using two new transformations. One concerns assignments of the form $f := g$ called copy statements, or copies for short. Had we gone into more detail in Example 10.2, copies would have arisen much sooner, because the algorithm for eliminating common sub expressions introduces them, as do several other algorithms. For example, when the common sub expression in $c := d + e$ is eliminated in Fig., the algorithm uses a new variable t to hold the value of $d + e$. Since control may reach $c := d + e$ either after the assignment to a or after the assignment to b , it would be incorrect to replace $c := d + e$ by either $c := a$ or by $c := b$. The idea behind the copy-propagation transformation is to use g for f , wherever possible after the copy statement $f := g$. For example, the assignment $x := t3$ in block B5 of Fig. is a copy. Copy propagation applied to B5 yields:

$$\begin{aligned}x &:= t3 \\ a[t2] &:= t5 \\ a[t4] &:= t3\end{aligned}$$

goto B2 Copies introduced during common subexpression elimination. This may not appear to be an improvement, but as we shall see, it gives us the opportunity to eliminate the assignment to x .

8.2 DEAD-CODE ELIMINATIONS

A variable is live at a point in a program if its value can be used subsequently; otherwise, it is dead at that point. A related idea is dead or useless code, statements that compute values that never get used. While the programmer is unlikely to introduce any dead code intentionally, it may appear as the result of previous transformations. For example, we discussed the use of debug that is set to true or false at various points in the program, and used in statements like `If (debug) print`. By a data-flow analysis, it may be possible to deduce that each time the program reaches this statement, the value of debug is false. Usually, it is because there is one particular statement `Debug :=false`

That we can deduce to be the last assignment to debug prior to the test no matter what sequence of branches the program actually takes. If copy propagation replaces debug by false, then the `print` statement is dead because it cannot be reached. We can eliminate both the test and printing from the object code. More generally, deducing at compile time that the value of an expression is a constant and using the constant instead is known as constant folding. One advantage of copy propagation is that it often turns the copy statement into dead code. For example, copy propagation followed by dead-code elimination removes the assignment to x and transforms 1.1 into

```
a [t2 ] :=
t5 a [t4] :=
t3 goto B2
```

8.3 PEEPHOLE OPTIMIZATION

A statement-by-statement code-generations strategy often produce target code that contains redundant instructions and suboptimal constructs .The quality of such target code can be improved by applying “optimizing” transformations to the target program.

A simple but effective technique for improving the target code is peephole optimization, a method for trying to improving the performance of the target program by examining a short sequence of target instructions (called the peephole) and replacing these instructions by a shorter or faster sequence, whenever possible.

JBIET

The peephole is a small, moving window on the target program. The code in the peephole need not contiguous, although some implementations do require this. We shall give the following examples of program transformations that are characteristic of peephole optimizations:

- Redundant-instructions elimination
- Flow-of-control optimizations
- Algebraic simplifications
- Use of machine idioms

REDUNTANT LOADS AND STORES

If we see the instructions sequence

(1) (1) MOV R0,a

(2) (2) MOV a,R0

-we can delete instructions (2) because whenever (2) is executed. (1) will ensure that the value of a is already in register R0.If (2) had a label we could not be sure that (1) was always executed immediately before (2) and so we could not remove (2).

UNREACHABLE CODE

Another opportunity for peephole optimizations is the removal of unreachable instructions. An unlabeled instruction immediately following an unconditional jump may be removed. This operation can be repeated to eliminate a sequence of instructions. For example, for debugging purposes, a large program may have within it certain segments that are executed only if a variable debug is 1.In C, the source code might look like:

```
#define debug 0
```

```
....
```

```
If ( debug ) {
```

```
Print debugging information
```

```
}
```

In the intermediate representations the if-statement may be translated as:

```
If debug =1 goto L2
```

```
Goto L2
```

```
L1: print debugging information
```

JBIET

L2:(a)

One obvious peephole optimization is to eliminate jumps over jumps. Thus no matter what the value of debug; (a) can be replaced by:

If debug \neq 1 goto L2

Print debugging information

L2:(b)

As the argument of the statement of (b) evaluates to a constant true it can be replaced by

If debug \neq 0 goto L2

Print debugging information

L2:(c)

As the argument of the first statement of (c) evaluates to a constant true, it can be replaced by goto L2. Then all the statement that print debugging aids are manifestly unreachable and can be eliminated one at a time.

8.4 FLOW-OF-CONTROL OPTIMIZATIONS

The unnecessary jumps can be eliminated in either the intermediate code or the target code by the following types of peephole optimizations. We can replace the jump sequence

goto L2

....

L1 : gotoL2

by the sequence

goto L2

....

L1 : goto L2

If there are now no jumps to L1, then it may be possible to eliminate the statement L1:goto L2 provided it is preceded by an unconditional jump. Similarly, the sequence

if a < b goto L1

....

JBIET

L1 : goto L2

can be replaced by

if a < b goto L2

....

L1 : goto L2

Finally, suppose there is only one jump to L1 and L1 is preceded by an unconditional goto.

Then the sequence

goto L1

.....

L1:if a<b goto L2

L3:(1)

may be replaced by

if a<b goto

L2 goto L3

.....

L3:(2)

While the number of instructions in (1) and (2) is the same, we sometimes skip the unconditional jump in (2), but never in (1). Thus (2) is superior to (1) in execution time

8.5 REGISTER ALLOCATION

Instructions involving register operands are usually shorter and faster than those involving operands in memory. Therefore, efficient utilization of register is particularly important in generating good code. The use of registers is often subdivided into two sub problems:

1. During register allocation, we select the set of variables that will reside in registers at a point in the program.
2. During a subsequent register assignment phase, we pick the specific register that a variable will reside in. Finding an optimal assignment of registers to variables is difficult, even with single register values. Mathematically, the problem is NP-complete. The problem is further complicated because the hardware and/or the operating system of the target machine may require that certain register usage conventions be observed.

JBLET

Certain machines require register pairs (an even and next odd numbered register) for some operands and results. For example, in the IBM System/370 machines integer multiplication and integer division involve register pairs. The multiplication instruction is of the form M x, y where x, is the multiplicand, is the even register of an even/odd register pair.

The multiplicand value is taken from the odd register pair. The multiplier y is a single register. The product occupies the entire even/odd register pair.

The division instruction is of the form D x, y where the 64-bit dividend occupies an even/odd register pair whose even register is x; y represents the divisor. After division, the even register holds the remainder and the odd register the quotient. Now consider the two three address code sequences (a) and (b) in which the only difference is

the operator in the second statement. The shortest assembly sequence for (a) and (b) are given in(c). Ri stands for register i. L, ST and A stand for load, store and add respectively.

The optimal choice for the register into which 'a' is to be loaded depends on what will ultimately happen to e.

```
t := a + b t := a +
b t := t * c t := t +
c t := t / d t := t / d
```

(a) (b)

Two three address code sequences L R1, a L R0, a

A R1, b A R0, b

M R0, c A R0, c

D R0, d SRDA R0,

ST R1, t D R0, d

ST R1, t

(a) (b)

8.6 CHOICE OF OF EVALUATION ORDER

The order in which computations are performed can affect the efficiency of the target code. Some computation orders require fewer registers to hold intermediate results than others. Picking a best order is another difficult, NP-complete problem. Initially, we shall avoid the

problem by generating code for the three -address statements in the order in which they have been produced by the intermediate code generator.

8.7 APPROCHES TO CODE GENERATION

The most important criterion for a code generator is that it produce correct code. Correctness takes on special significance because of the number of special cases that code generator must face. Given the premium on correctness, designing a code generator so it can be easily implemented, tested, and maintained is an important design goal Reference Counting Garbage Collection The difficulty in garbage collection is not the actual process of collecting the garbage--it is the problem of finding the garbage in the first place. An object is considered to be garbage when no references to that object exist. But how can we tell when no references to an object exist? A simple expedient is to keep track in each object of the total number of references to that object. That is, we add a special field to each object called a reference count . The idea is that the reference count field is not accessible to the Java program. Instead, the reference count field is updated by the Java virtual machine itself.

Consider the statement

Object p = new Integer (57);

which creates a new instance of the Integer class. Only a single variable, p, refers to the object. Thus, its reference count should be one.

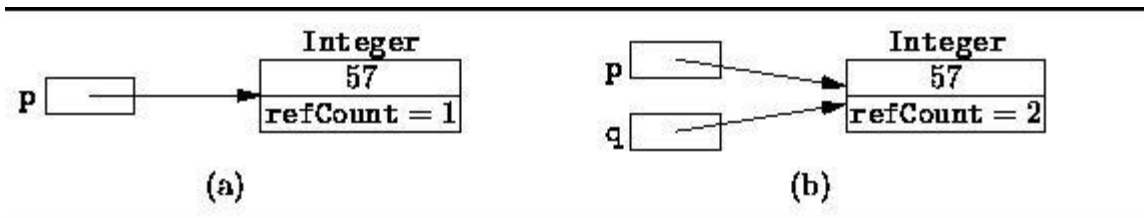

Figure: Objects with reference counters.

Now consider the following sequence of statements: Object p = new Integer (57);

Object q = p;

This sequence creates a single Integer instance. Both p and q refer to the same object. Therefore, its reference count should be two.

In general, every time one reference variable is assigned to another, it may be necessary to update several reference counts. Suppose p and q are both reference variables. The assignment

p = q;

would be implemented by the Java virtual machine as follows:

```

if (p != q)
{
    if (p != null) --
        p.refCount;

    p = q;

    if (p != null)
        ++p.refCount;
}
    
```

For example suppose p and q are initialized as follows:

Object p = new Integer (57);

Object q = new Integer (99);

As shown in Figure (a), two Integer objects are created, each with a reference count of one. Now, suppose we assign q to p using the code sequence given above. Figure (b) shows that after the assignment, both p and q refer to the same object--its reference count is two. And the reference count on Integer(57) has gone to zero which indicates that it is garbage.

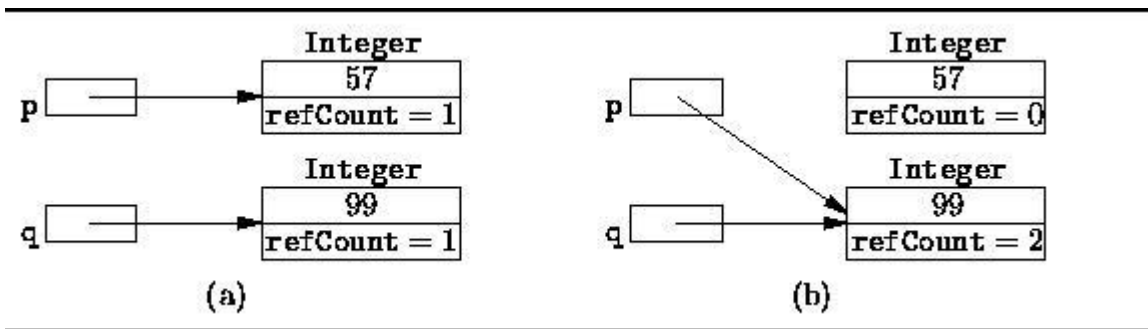

Figure: Reference counts before and after the assignment p = q.

The costs of using reference counts are twofold: First, every object requires the special reference count field. Typically, this means an extra word of storage must be allocated in each object. Second, every time one reference is assigned to another, the reference counts

JBLET

must be adjusted as above. This increases significantly the time taken by assignment statements.

The advantage of using reference counts is that garbage is easily identified. When it becomes necessary to reclaim the storage from unused objects, the garbage collector needs only to examine the reference count fields of all the objects that have been created by the program. If the reference count is zero, the object is garbage.

It is not necessary to wait until there is insufficient memory before initiating the garbage collection process. We can reclaim memory used by an object immediately when its reference goes to zero. Consider what happens if we implement the Java assignment $p = q$ in the Java virtual machine as follows:

```
if (p != q)
{
    if (p != null)
        if (--p.refCount == 0)
            heap.release (p);
    p = q;
    if (p != null)
        ++p.refCount;
}
```

Notice that the release method is invoked immediately when the reference count of an object goes to zero, i.e., when it becomes garbage. In this way, garbage may be collected incrementally as it is created.

TEXT BOOKS:

1. Compilers, Principles Techniques and Tools- Alfred V Aho, Monical S Lam, Ravi Sethi, Jeffrey D. Ullman, 2nd ed, Pearson, 2007.
2. Principles of compiler design, V. Raghavan, 2nd ed, TMH, 2011.
3. Principles of compiler design, 2nd ed, Nandini Prasad, Elsevier

REFERENCE BOOKS:

1. <http://www.nptel.iitm.ac.in/downloads/106108052/>
2. Compiler construction, Principles and Practice, Kenneth C Loudon, CENGAGE
3. Implementations of Compiler, A new approach to Compilers including the algebraic methods, Yunlinsu, SPRINGER